

PLANT LAYOUT AND MATERIAL HANDLING

IV B.TECH. II SEM (MR16)

**DEPARTMENT OF MECHANICAL ENGINEERING
MALLA REDDY ENGINEERING COLLEGE**

SYLLABUS**UNIT -I**

Introduction – classification of layout, advantages and limitations of different layouts, layout design procedures, over view of the plant layout.

Process lay out and product lay out selection, specification, implementations and fallow up comparison of product and process lay out

UNIT-II

Heuristics for plant layout-ALDEP, CORELAP, CRAFT, Group Layout, Fixed position layout- Quadratic assignment model. Branch and bound method

UNIT-III

Introduction, material handling systems: selection, material handling principles, classification of material handling equipment, relationship of material handling to plant layout.

UNIT-IV

Basic material handling systems: Selection, Material handling method – path, Equipment, Function orientated systems

UNIT-V

Methods to minimize cost of material handling- Maintenance of material handling equipments, safety in handling ergonomics of material handling equipment. Design, miscellaneous equipments.

UNIT –I

Introduction – classification of layout, advantages and limitations of different layouts, layout design procedures, over view of the plant layout.
Process lay out and product lay out selection, specification, implementations and fallow up comparison of product and process lay out

A plant layout can be defined as follows:

Plant layout refers to the arrangement of physical facilities such as machinery, equipment, furniture etc. within the factory building in such a manner so as to have quickest flow of material at the lowest cost and with the least amount of handling in processing the product from the receipt of material to the shipment of the finished product.

PLANT LAYOUT CAN BE DEFINED IN MANY WAYS LIKE

According to More” plant lay out is a plan of optimum arrangement of facilities including personal, operating equipment storage space material handling equipment and all other supporting services along with design of best structure to contain all these facilities’

According to Riggs, “the overall objective of plant layout is to design a physical arrangement that most economically meets the required output – quantity and quality.”

According to J. L. Zundi, “Plant layout ideally involves allocation of space and arrangement of equipment in such a manner that overall operating costs are minimized.

Plant layout is an important decision as it represents long-term commitment. An ideal plant layout should provide the optimum relationship among output, floor area and manufacturing process. It facilitates the production process, minimizes material handling, time and cost, and allows flexibility of operations, easy production flow, makes economic use of the building, promotes effective utilization of manpower, and provides for employee’s convenience, safety, Comfort at work, maximum exposure to natural light and

ventilation. It is also important because it affects the flow of material and processes, labour efficiency, supervision and control, use of space and expansion possibilities etc.

THE MAIN OBJECTIVES OF PLANT LAYOUT

The main goal of the plant layout is to maximize the profit by arrangement of all the plant facilities to the best advantage of total manufacturing of the product

The objectives of plant layout are:

1. Streamline the flow of materials through the plant.
2. Facilitate the manufacturing process.
3. Maintain high turnover of in-process inventory.
4. Minimize materials handling and cost.
5. Effective utilization of men, equipment and space.
6. Make effective utilization of cubic space.
7. Flexibility of manufacturing operations and arrangements.
8. Provide for employee convenience, safety and comfort.
9. Minimize investment in equipment.
10. Minimize overall production time.
11. Maintain flexibility of arrangement and operation.
12. Facilitate the organizational structure

TYPES OF LAYOUT

As discussed so far the plant layout facilitates the arrangement of machines, equipment and other physical facilities in a planned manner within the factory premises. An entrepreneur must possess an expertise to lay down a proper layout for new or existing plants. It differs from plant to plant, from location to location and from industry to industry. But the basic principles governing plant layout are more or less same. As far as small business is

concerned, it requires a smaller area or space and can be located in any kind of building as long as the space is available and it is convenient. Plant layout for Small Scale business is closely linked with the factory building and built up area.

From the point of view of plant layout, we can classify small business or unit into Three types

- 1 manufacturing unit
- 2 Traders
- 3 service establishments

MANUFACTURING UNIT

In this manufacturing unit plant layout may be of four types

- (a) Product or line layout
- (b) Process or functional layout
- (c) Fixed position or location layout
- (d) Combined or group layout

PRODUCT OR LINE LAYOUT:

It is appropriate for producing one standardized product, usually in large volume. It is also called as flow-shop layout or straight line layouts. The machines are arranged according to the progressive steps by which the product is made.

Example: chemical, paper, rubber, refineries, cement industry, quarry under this, machines and equipments are arranged in one line depending upon the sequence of operations required for the product.

The materials move from one Workstation to another sequentially without any backtracking or deviation. Under this, machines are grouped in one sequence. Therefore materials are fed into the first machine and finished goods travel automatically from machine to machine, the output of one machine

becoming input of the next, e.g. in a paper mill, bamboos are fed into the machine at one end and paper comes out at the other end. The raw material moves very fast from one workstation to other stations with a Minimum work in progress storage and material handling.

The grouping of machines should be done keeping in mind the following general principles.

- a) All the machine tools or other items of equipments must be placed at the point demanded by the sequence of operations
- b) There should no points where one line crossed another line.
- c) Materials may be fed where they are required for assembly but not necessarily at one point.
- d) All the operations including assembly, testing packing must be included in the line

A line layout for two products is given below.

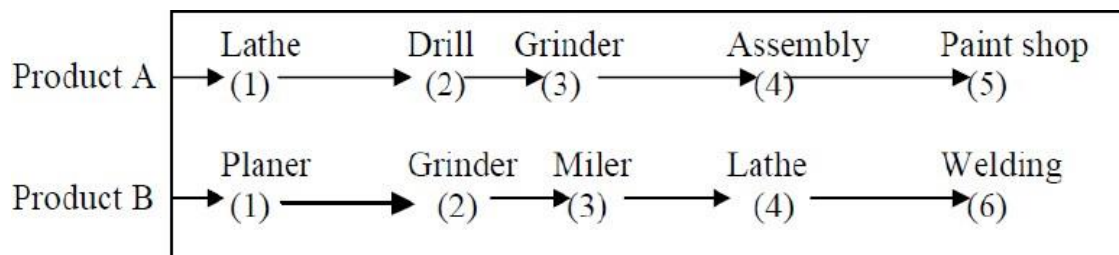

ADVANTAGES: Product layout provides the following benefits:

- a) Low cost of material handling, due to straight and short route and absence of Backtracking
- b) Smooth and uninterrupted operations
- c) Continuous flow of work
- d) Lesser investment in inventory and work in progress
- e) Optimum use of floor space

- f) Shorter processing time or quicker output
- g) Less congestion of work in the process
- h) Simple and effective inspection of work and simplified production control
- i) Lower cost of manufacturing per unit

DISADVANTAGES: Product layout suffers from following drawbacks:

- a. High initial capital investment in special purpose machine
- b. Heavy overhead charges
- c. Breakdown of one machine will hamper the whole production process
- d. Lesser flexibility as specially laid out for particular product.

SUITABILITY: Product layout is useful under following conditions:

- 1) Mass production of standardized products
- 2) Simple and repetitive manufacturing process
- 3) Operation time for different process is more or less equal
- 4) Reasonably stable demand for the product
- 5) Continuous supply of materials

Therefore, the manufacturing units involving continuous manufacturing process, producing few standardized products continuously on the firm's own specifications and in anticipation of sales would prefer product layout e.g. chemicals, sugar, paper, rubber, refineries, cement, automobiles, food processing and electronics etc.

PROCESS LAYOUT:

In this type of layout machines of a similar type are arranged together at one place.

E.g. Machines performing drilling operations are arranged in the drilling department, machines performing casting operations be grouped in the casting department. Therefore the machines are installed in the plants, which follow the

process layout. Hence, such layouts typically have drilling department, milling department, welding department, heating department and painting department etc.

The process or functional layout is followed from historical period. It evolved from the handicraft method of production. The work has to be allocated to each Department in such a way that no machines are chosen to do as many different job as possible i.e. the emphasis is on general purpose machine. The work, which has to be done, is allocated to the machines according to loading schedules with the object of ensuring that each machine is fully loaded.

Suitable when product having standard features is to be produced in large volumes.

The specialized machines and equipments are arranged one after another in the order of sequence required in the production process.

Process layout is shown in the following diagram.

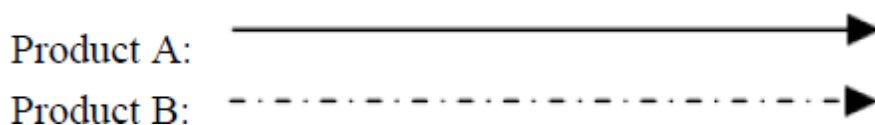
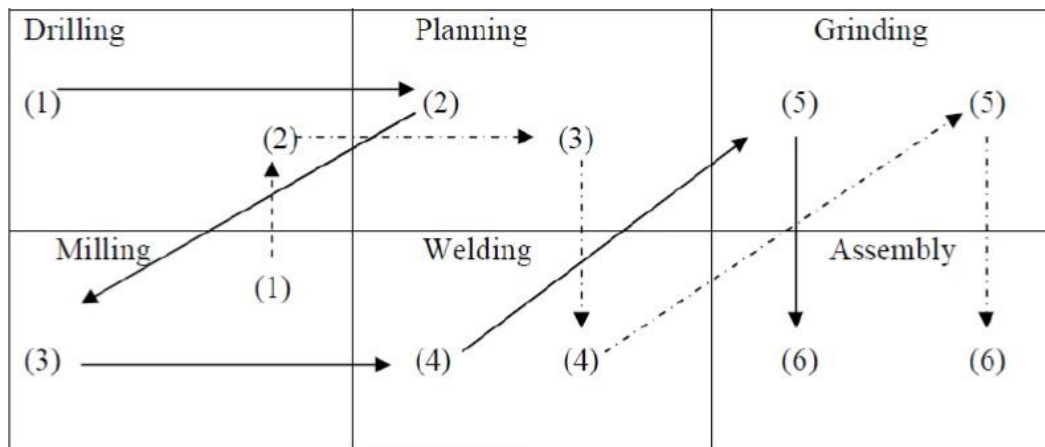

Process layout showing movement of two products The grouping of machines according to the process has to be done keeping in mind the following principles

- a) The distance between departments should be as short as possible for avoiding long distance movement of materials

- b) The departments should be in sequence of operations
- c) The arrangement should be convenient for inspection and supervision

ADVANTAGES: Process layout provides the following benefits

- a) Lower initial capital investment in machines and equipments. There is high degree of machine utilization, as a machine is not blocked for a single product
- b) The overhead costs are relatively low
- c) Change in output design and volume can be more easily adapted to the output of variety of products
- d) Breakdown of one machine does not result in complete work stoppage
- e) Supervision can be more effective and specialized
- f) There is a greater flexibility of scope for expansion.

DISADVANTAGES: Product layout suffers from following drawbacks

- a. Material handling costs are high due to backtracking
- b. More skilled labour is required resulting in higher cost.
- c. Time gap or lag in production is higher
- d. Work in progress inventory is high needing greater storage space
- e. More frequent inspection is needed which results in costly supervision

Suitability: Process layout is adopted when

- 1. Products are not standardized
- 2. Quantity produced is small
- 3. There are frequent changes in design and style of product
- 4. Job shop type of work is done
- 5. Machines are very expensive

Thus, process layout or functional layout is suitable for job order production involving non-repetitive processes and customer specifications and

non standardized products, e.g. tailoring, light and heavy engineering products, made to order furniture industries, jewellery.

COMBINATION LAYOUT:

A combination of process and product layout combines the advantages of both types of layouts. A combination of layout is possible where an item is being made in different types and sizes. Here machinery is arranged in a process layout but the process grouping is then arranged in a sequence to manufacture various types and sizes of products. It is to be noted that the sequence of operation remains the same with the variety of products and sizes of operation.

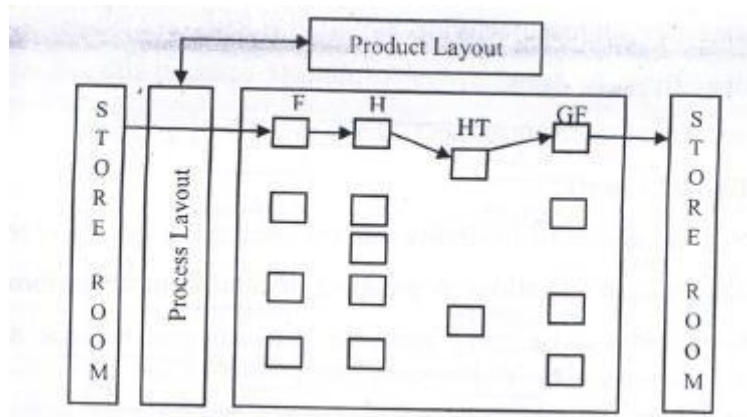

F Forging Hammer

H Hobbing machine

HT Heat treatment Furnace

GF gear finishing machine

FIXED POSITION OR LOCATION LAYOUT:

Fixed-position layout: An arrangement in which service or manufacturing site is fixed in place; employees along with their equipment, come to the site to do their work.

When due to size, shape and other characteristics constraints, the products cannot be moved, the machine and operators move around the product.

Example: construction of a building, assemble of an aircraft or ship.

In this type of layout, the major product being produced is fixed at one location. Equipment labour and components are moved to that location. All facilities are Brought and arranged around one work centre. This type of layout is not relevant for small scale entrepreneur. The following figure shows a fixed position layout regarding shipbuilding.

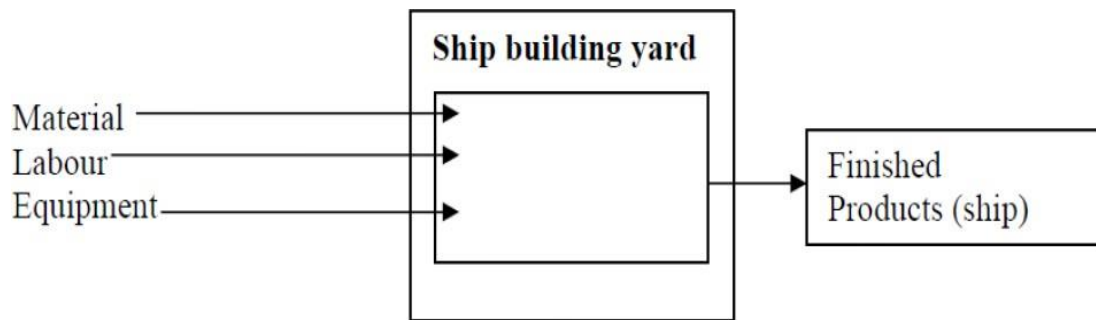

Fixed position Layout

ADVANTAGES: Fixed position layout provides the following benefits

- a) It saves time and cost involved on the movement of work from one workstation to another.
- b) The layout is flexible as change in job design and operation sequence can be easily incorporated.
- c) It is more economical when several orders in different stages of progress are Being executed simultaneously.
- d) Adjustments can be made to meet shortage of materials or absence of worker by changing the sequence of operations.

DISADVANTAGES: Fixed position layout has the following drawbacks

- a. Production period being very long, capital investment is very heavy
- b. Very large space is required for storage of material and equipment near the product.
- c. As several operations are often carried out simultaneously, there is possibility of confusion and conflicts among different workgroups.

SUITABILITY: The fixed position layout is followed in following conditions

1. Manufacture of bulky and heavy products such as locomotives, ships, boilers, generators, wagon building, aircraft manufacturing, etc.
2. Construction of building, flyovers, dams.
3. Hospital, the medicines, doctors and nurses are taken to the patient (product).

GROUP TECHNOLOGY (CELLULAR LAY OUT)

Group Technology (GT) is an option for achieving line-flow layouts with low-volume processes; this technique creates cells not limited to just one worker and has a unique way of selecting work to be done by the cell.

The GT method groups parts or products with similar characteristics into families and sets aside groups of machines for their production.

Grouping technology layout of cellular manufacturing layout is made for a single part family i.e. parts with common characteristics. In this layout dissimilar machines are grouped into cells and each cell functions like product layout. Certain manufacturing units may require all three processes namely intermittent.

Before group technology

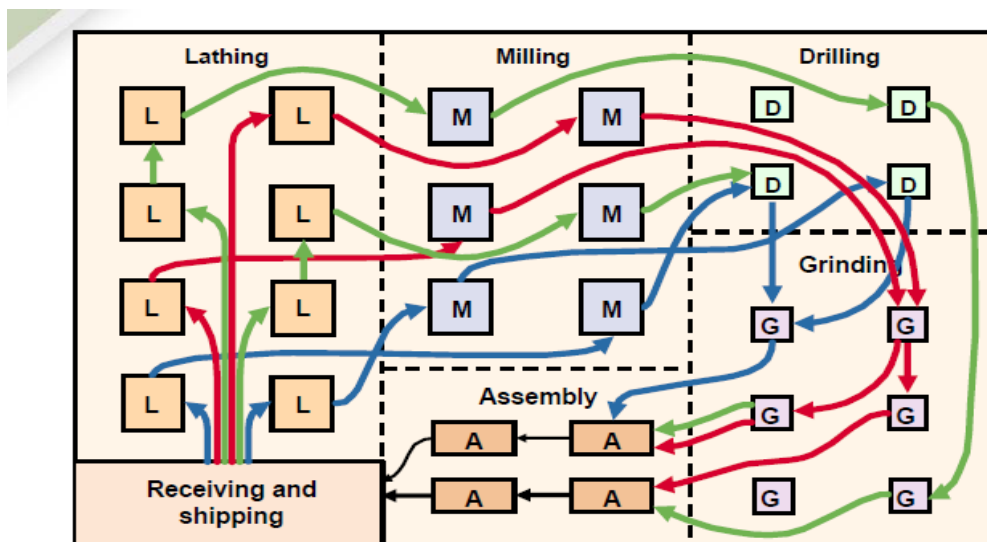

After Group Technology

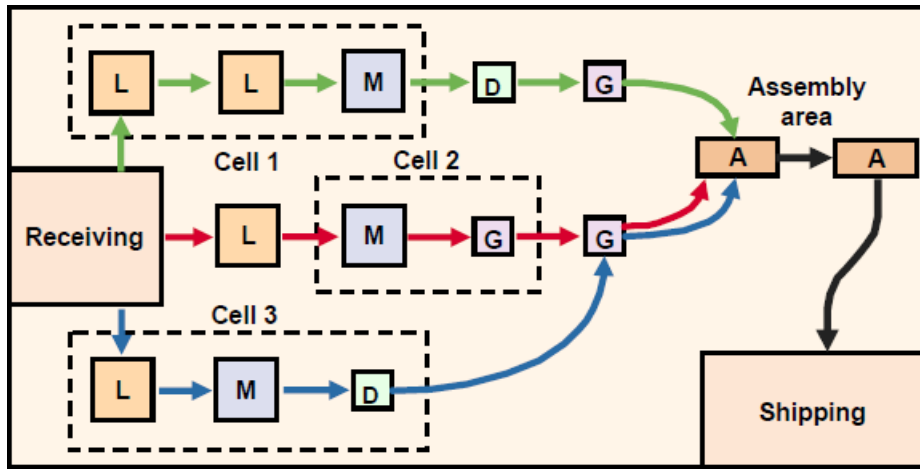

Process (job shops), the continuous process (mass production shops) and the representative process combined process [i.e. miscellaneous shops]. In most of industries, only a product layout or process layout or fixed location layout does not exist. Thus, in manufacturing concerns where several products are produced in repeated numbers with no likelihood of continuous production, Combined layout is followed. Generally, a combination of the product and process layout or other combination are found, in practice, e.g. for industries involving the fabrication of parts and assembly, fabrication tends to employ the process layout, while the assembly areas often employ the product layout. In soap, manufacturing plant, the machinery manufacturing soap is arranged on the product line principle, but ancillary services such as heating, the manufacturing of glycerine, the power house, the water treatment plant etc. are arranged on a Functional basis.

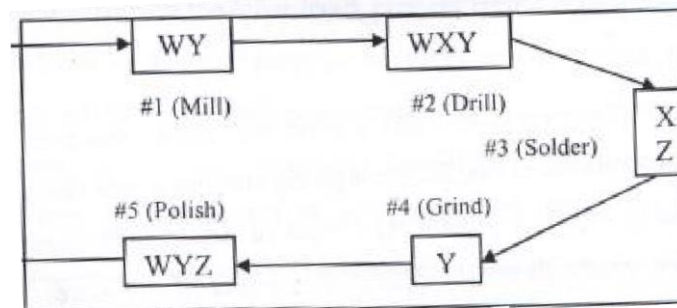

Group layout OR Cellular layout

Advantage and Disadvantages:

It reduces material handling cost and simplifies machine changeovers. It reduces in-process inventory and automate the production but reduces the flexibility.

TRADERS

When two outlets carry almost same merchandise, customer's visuals buy in the one that is more appealing to them. Thus the customers are attracted and kept by good layout that is good lighting attractive colours, good ventilation, air conditioning, modern design and arrangement and even music. All of these things mean customer convenience, customer appeal and volume

The customer is always impressed by a service and efficiency and quality. Hence, the layout is essential for handling merchandise which arranged as per the space available and the type and magnitude of goods to be sold keeping in mind the convenience of customers.

There are three kinds of layouts in retail operations to day

1. Self service or modified self service layout
2. Full service layout
3. Special layout

SERVICE CANTERS AND ESTABLISHMENTS

Service establishments as such as Hotels, restaurants must give due attentions to client convenience, quality of services, efficiency in delivering services and pleasing office ambience. In today's environment the client look for ease in approaching different departments of a service organisation and hence the layout should be design in a fashion, which allows clients quick and convenient access to the facilities offered a service establishments

FACTORS INFLUENCING LAYOUT

While deciding his factory or unit or establishment or store, a small-scale businessman should keep the following factors in mind:

- a) Factory building: The nature and size of the building determines the floor space available for layout. While designing the special requirements, e.g. air conditioning, dust control, humidity control etc. must be kept in mind.
- b) Nature of product: product layout is suitable for uniform products whereas process layout is more appropriate for custom-made products.
- c) Production process: In assembly line industries, product layout is better. In job order or intermittent manufacturing on the other hand, process layout is desirable.
- d) Type of machinery: General purpose machines are often arranged as per process layout while special purpose machines are arranged according to product layout
- e) Repairs and maintenance: machines should be so arranged that adequate space is available between them for movement of equipment and people required for repairing the machines.
- f) Human needs: Adequate arrangement should be made for cloakroom, washroom, lockers, drinking water, toilets and other employee facilities, proper provision should be made for disposal of effluents, if any.
- g) Plant environment: Heat, light, noise, ventilation and other aspects should be Duly considered, e.g. paint shops and plating section should be located in another hall so that dangerous fumes can be removed through proper Ventilation etc. Adequate safety arrangement should also be made.

Thus, the layout should be conducive to health and safety of employees. It should ensure free and efficient flow of men and materials. Future expansion and diversification may also be considered while planning factory layout.

DESIGN OF PROCESS LAYOUT

Analysis involved the design of production lines and assembly lines relates primarily to timing , coordinates And balance among individual stages in the process, for process layouts , the relative arrangement of departments and machine is critical factor because of the large amount of transportation and handling involved.

PROCEDURE FOR DESIGNING PROCESS LAY OUTS

The process layout determines the best relative location of functional work canters. Work centre that interact frequently, with movement of material or people should be located close to gather, where as those that have little interaction can be specially separated. One approach of designing an efficient functional layout is described below

1. List and describe each functional work centre
2. Obtain a drawing and description of the facility being designed
3. Identify and estimate the amount of material and personal flow among work centre
4. use structured analytical methods to obtain a good general layout
5. evaluate and modify the layout, incorporating details such as machine orientations, storage area location and equipment access

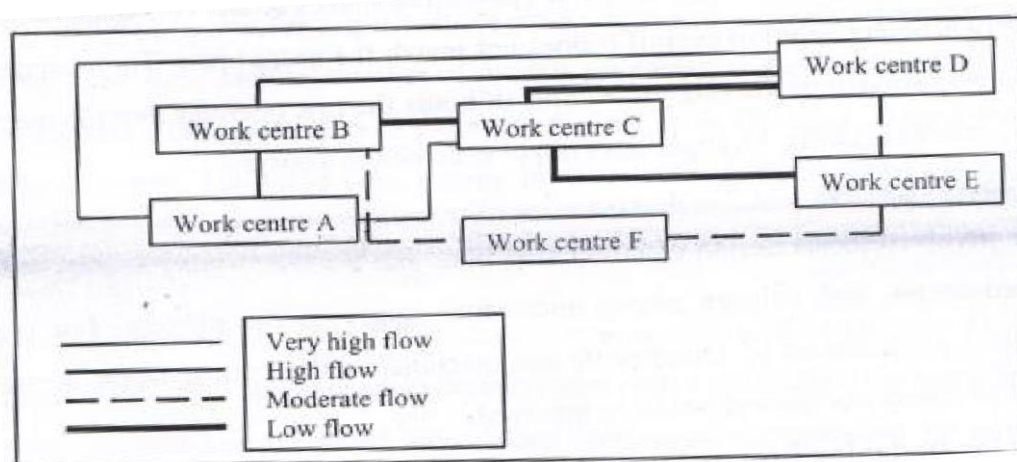

Relationship flow diagram

Layout design procedures can be classified into manual methods and computerised methods

Manual methods: Under this category there are some conventional methods like travel chart and systematic layout planning (SLP).

Computerized methods: Under this method again the layout design procedures can be classified into constructive type algorithms and improvement type algorithms.

Construction type algorithms

- Automated layout design program (ALDEP)
- Computerized relationship layout planning (CORELAP)

Improvement type algorithms

- Computerized relative allocation of facilities technique (CRAFT)

APPLICABILITY OF PLANT LAYOUT

Plant layout is applicable to all types of industries or plants. Certain plants require special arrangements which, when incorporated make the layout look distinct from the types already discussed above. Applicability of plant layout in Manufacturing and service industries is discussed below. In case of the manufacturing of detergent powder, a multi-storey building is specially constructed to house the boiler. Materials are stored and poured into the boiler at different stages on different floors. Other facilities are also provided Around the boiler at different stations. Another applicability of this layout is the manufacture of talcum powder. Here machinery is arranged vertically i.e. from top to bottom. Thus, material is poured into the first machine at the top and powder comes out at the bottom of the machinery located on the ground floor. Yet another applicability of this layout is the newspaper plant, where the time Element is of supreme importance, the accomplishment being gapped in seconds. Here plant layout must be simple and direct so as to eliminate distance, delay and confusion.

There must be a perfect coordination of all departments and machinery or equipments, as materials must never fail. Plant layout is also applicable to five star hotels as well. Here lodging, bar, restaurant, kitchen, stores, swimming pool, laundry, shaving saloons, shopping arcades, conference hall, parking areas etc. should all find an appropriate place in the layout. Here importance must be given to cleanliness, elegant appearance, convenience and compact looks, which attract customers. Similarly plant layout is applicable to a cinema hall, where emphasis is on comfort, and convenience of the cinemagoers. The projector, screen, sound box, fire fighting equipment, ambience etc. should be of utmost importance.

A plant layout applies besides the grouping of machinery, to an arrangement for other facilities as well. Such facilities include receiving and dispatching points, Inspection facilities, employee facilities, storage etc. Generally, the receiving and the dispatching departments should be at either end of the plant. The storeroom should be located close to the production, receiving and dispatching centres in order to minimize handling costs. The inspection should be right next to other dispatch department as inspections are done finally, before dispatch. The maintenance department consisting of lighting, safety devices, fire protection, collection and disposal of garbage, scrap etc. should be located in a place which is easily accessible to all the other departments in the plant. The other employee facilities like toilet facilities, drinking water facilities, first aid room, cafeteria etc. Can be a little away from other departments but should be within easy reach of the employees. Hence, there are the other industries or plants to which plant layout is applicable.

UNIT-II

Heuristics for plant layout-ALDEP, CORELAP, CRAFT, Group Layout, Fixed position layout- Quadratic assignment model.
Branch and bound method

AUTOMATED LAYOUT DESIGN PROGRAM (ALDEP)

Now we will examine Automated Layout Design Program (ALDEP).ALDEP is basically a construction algorithm but it can also be used to evaluate two layouts. The algorithm uses basic data on facilities and builds a layout by successively placing the layout using relationship information between the departments.

The basic inputs to ALDEP are

1. Length and width of facility.
2. Area of each department.
3. Minimum closeness preference (MCP) value..
4. Sweep width.
5. Relationship chart showing the closeness rating.
6. Location and size of any restricted area.

The procedures adopted for using ALDEP are:

Step 1: Input the following: 1. Length and width of facility. 2. Area of each department. 3. Minimum closeness preference (MCP) value. 4. Sweep width. 5. Relationship chart showing the Closeness rating. 6. Location and size of restricted area.

Step 2: One department is selected randomly and placed in the layout.

Step 3: In this step, the algorithm uses minimum closeness required between departments for the selection of departments to be placed with an earlier placed department. Select the department having maximum closeness rating. If there is no department having minimum closeness preference, then any department that remains to be placed is selected.

Step 4: If all the departments are placed in the layout, Go to step 5. Else, Go to step 3.

Step 5: Compute the total score of the layout.

Step 6: If the total score required is the acceptable score, then Go to step 7, else Go to step 2.

Step 7: Print the current layout and the corresponding score.

Computerized Relationship Layout Planning (CORELAP)

This algorithm is based on Muther's procedure given in systematic Layout Planning. A computer algorithm was developed by R.C. Lee. Interactive version was developed by James Moore.

Input requirements

- Number of departments and their area.
- Closeness relationship as given by REL-chart.
- weighted rating for REL-chart entries.

Optional input information

- Scale of output.
- Building length to width ratio.
- Department pre-assignment.

General approach is to select the most critical department first, and place it at the centre of the layout.

After the first department is placed, then the department having highest closeness relationship with the department which are already placed is selected and placed in the best location adjacent to the previously placed departments. CORELAP builds the layout from centre. The final layout will not have a regular rectangular shape. The user has to modify it slightly to suit the situation

Final score of the layout is developed by using the closeness values and rectilinear distances between all pairs of the departments.

CORELAP algorithm: the following are the major steps of CORELAP algorithm.\

1. Defining basic data.
2. Determination of placement of order.
3. Placement of department s in the layout.
4. Finding the total score of the layout.

Computerized Relative Allocation of Facilities Technique (CRAFT)

CRAFT (Buffa et al., 1964) is a computerized heuristic algorithm that takes in load matrix of interdepartmental flow and transaction costs with a representation of a block layout as the inputs. The block layout could either be an existing layout or; for a new facility, any arbitrary initial layout.

The algorithm then computes the departmental locations and returns an estimate of the total interaction costs for the initial layout. The Governing algorithm is designed to compute the impact on a cost measure for two-way or three-way swapping in the location of the facilities. For each swap, the various interaction costs are computed afresh and the load matrix and the change in cost (increase or decrease) is noted and stored in the RAM. The algorithm proceeds this way through all possible combinations of swaps accommodated by the software. The basic procedure is repeated a number of times resulting in a more efficient block layout every time till such time when no further cost reduction is possible. The final block layout is then printed out to serve as the basis for a

detailed layout template of the facilities at a later stage. Since its formulation, more powerful versions of CRAFT have been developed but these too follow the same, basic heuristic routine and therefore tend to be highly CPU-intensive.

The basic computational disadvantage of a CRAFT-type technique is that one always has got to start with an arbitrary initial solution. This means that there is no mathematical certainty of attaining the desired optimal solution after a given number of iterations. If the starting solution is quite close to the optimal solution by chance, then the final solution is attained only after a few iterations. However, as there is no guarantee that the starting solution will be close to the global optimum, the expected number of iterations required to arrive at the final solution tend to be quite large thereby straining computing resources. In our present paper we propose and illustrate the Modified Assignment (MASS) algorithm as an extension to the traditional CRAFT, to enable faster convergence to the optimal solution. This we propose to do by marrying CRAFT technique with the Hungarian assignment algorithm. As our proposed algorithm is semi-heuristic, it is likely to be less CPU-intensive than any traditional, purely heuristic CRAFT-type algorithm.

Features of CRAFT

The major features of CRAFT are as listed below:

Attempts to minimize transportation cost, where transportation cost = flow x distance x unit cost. Required the assumptions that:

- (1) Move costs are independent of the equipment utilization and
- (2) Move costs are linearly related to the length of the move.

Distance matrix used in the rectilinear distance between department centroids. CRAFT being a path-oriented method, the final layout is dependent

on the initial layout. Therefore, a number of different initial layouts should be used as input to the CRAFT layout. CRAFT allows the use of dummy departments to represent fixed areas in the layout.

CRAFT input requirements are:

1. Initial layout.
2. Flow data.
3. Cost per unit distance.
4. Total number of departments.
5. Fixed departments and their location.
6. Area of departments.

The procedures adopted for using CRAFT are:

1. Determine department centroids.
2. Calculate rectilinear distance between centroids.
3. Calculate transportation cost for the layout.
4. Consider department sharing a common border.
5. Determine transportation cost of each departmental interchange.
6. Select and implement the departmental interchange that offers the greatest reduction in transportation cost.
7. Repeat the procedure for the new layout until no interchange is able to reduce the transportation cost

Major disadvantages of using CRAFT

CRAFT, in spite of its popularity has some major drawbacks.

- Because the basis is the cost of materials handling, only production departments are considered. No service departments are considered.
- An initial idea of the layout is required. Therefore, the technique only applies to the modification of an existing layout or new layouts where the outline shape is known.
- The distances between the departments are taken as straight lines whereas in practice movement is usually rectangular along orthogonal lines.

To illustrate the approach to develop a layout, in CRAFT heuristics consider the initial layout and flow data as in the following example. Assume that the cost per unit transfer to be 1. Example

Consider the following layout problem with unit cost matrix. Use CRAFT algorithm to obtain layout. The initial layout is shown in figure below and the flow matrix in table?? ?

CRAFT Procedure:

The steps of CRAFT algorithm are summarized below.

1. Input:
 1. Number of departments
 2. Number of interchangeable departments
 3. Initial layout
 4. Cost matrix
 5. Flow matrix
 6. Area of the departments
2. Compute centroids of the departments in the present layout.
3. Form distance matrix using the centroids

4. Given data on flow, distance and cost, compute the total handling cost of the present layout.
5. Find all the possible pair-wise interchanges of the departments based on common border or equal area criterion. For each possibility, interchange the corresponding centroids and compute approximate costs.
6. Find the pair of departments corresponding to the minimum handling cost from among all the possible pairs of interchanges.
7. Is the cost in the previous step less than the total cost of the present layout?
If yes Go to step 8 if not Go to step 11.
8. Interchange the selected pair of department call this as new layout
Compute centroid, distance matrix and total cost
9. Is the cost of new layout is less then cost of present layout
If yes go to step 10 if not go to step 11
10. The new lay out is considered as the PRESENT LAYOUT its data on the centroida, layout matrix and the total cost is retained go to step 5
11. Print the present layout as the FINAL LAYOUT.
12. STOP.

Group Technology (cellular lay out)

Group Technology (GT) is an option for achieving line-flow layouts with low-volume processes; this technique creates cells not limited to just one worker and has a unique way of selecting work to be done by the cell. The GT method groups parts or products with similar characteristics into families and sets aside groups of machines for their production.

Grouping technology layout of cellular manufacturing layout is made for a single part family i.e. parts with common characteristics. In this layout dissimilar machines are grouped into cells and each cell functions like product

layout. Certain manufacturing units may require all three processes namely intermittent.

Before group technology

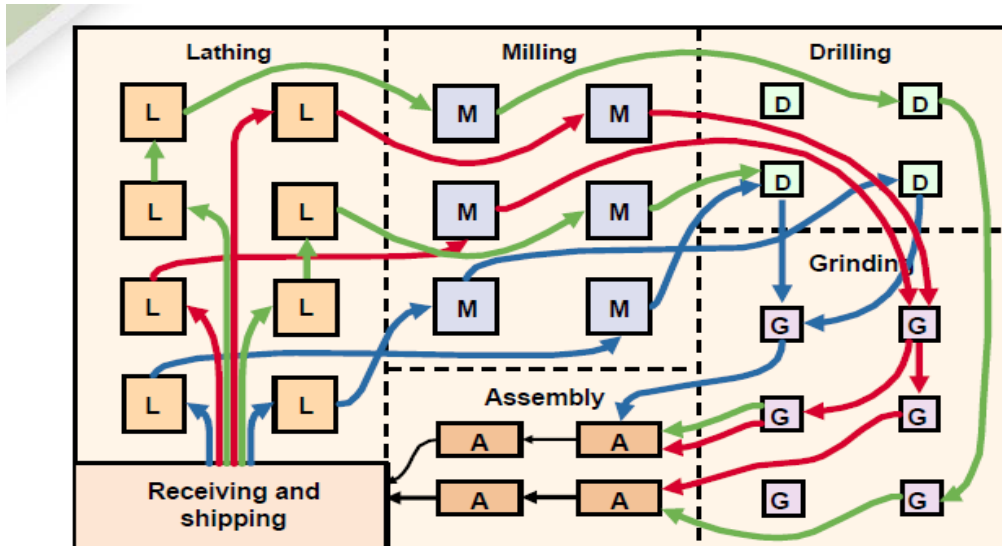

After Group Technology

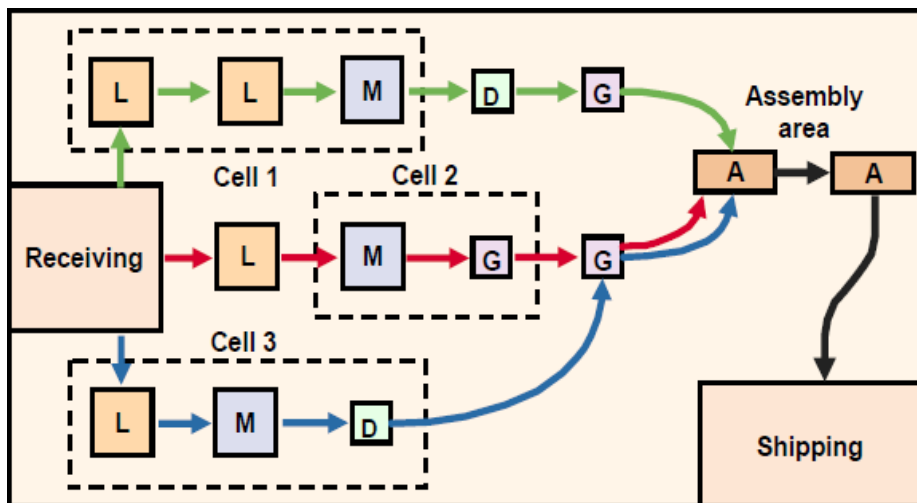

Process (job shops), the continuous process (mass production shops) and the representative process combined process [i.e. miscellaneous shops]. In most of industries, only a product layout or process layout or fixed location layout does not exist. Thus, in manufacturing concerns where several products are produced in repeated numbers with no likelihood of continuous production,

Combined layout is followed. Generally, a combination of the product and process layout or other combination are found, in practice, e.g. for industries involving the fabrication of parts and assembly, fabrication tends to employ the process layout, while the assembly areas often employ the product layout. In soap, manufacturing plant, the machinery manufacturing soap is arranged on the product line principle, but ancillary services such as heating, the manufacturing of glycerine, the power house, the water treatment plant etc. are arranged on a Functional basis.

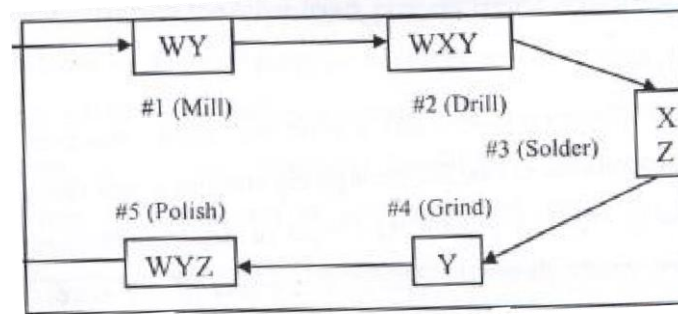

Group layout OR Cellular layout

Advantage and Disadvantages:

It reduces material handling cost and simplifies machine changeovers. It reduces in-process inventory and automate the production but reduces the flexibility.

Fixed-Position Layouts

- In fixed-position layouts, the materials or major components remain in a fixed position, and workers, materials, and equipment are moved as needed.
- Fixed-position layout is used when product is very bulky, heavy or fragile

- Fixed-position layouts are used in large construction projects (buildings, power plants, and dams), shipbuilding, and production of large aircraft and space mission rockets.
- Fixed-position layouts are widely used for farming, fire fighting, road building, home building, remodelling and repair.

Hybrid (mixed) Layouts

- Actually, most manufacturing facilities use a combination of layout types.
- An example of a hybrid layout is where departments are arranged according to the types of processes but the products flow through on a product layout.
- For instance, supermarket layouts are fundamentally of a process nature, and however we find most use fixed-path material-handling devices such as roller type conveyors both in the stockroom and at checkouts, and belt-type conveyors at the cash registers.
- Hospitals also use the basic process arrangement, although frequently patient care involves more of a fixed-position approach, in which nurses, doctors, medicines, and special equipment are brought to the patient

Quadratic Assignment Problem (QAP)

The more common mathematical formulation for intra-company location Problems (especially in case of job shop production) are the Quadratic Assignment Problem (QAP).

For the QAP the cost of an assignment is determined by the distances and the material flows between all given entities. While, in case of (Linear assignment problem) LAP the costs for assigning a machine to a location do not depend on the location chosen for any other machine we now want to take distances of locations and material flow between entities into account as well. In

fact, we are now going to minimize the total transportation costs occurring due to the chosen assignment whereas for the LAP we minimize isolated location-oriented costs.

An “Activity Relationship Charts” are useful graphical means of representing the desirability of locating pairs of machines/operations near to each other. The following letter codes have been suggested in literature for determining a “closeness” rating.

‘A’ absolutely necessary. Because two machines/operations use the same equipment or facilities, they must be located near each other.

E Especially important. The facilities may require to the same personnel or records.

I Important. The activities may be located in sequence in the normal work flow.

O Ordinary importance. It would be convenient to have the facilities near each other, but it is not essential.

U Unimportant. It does not matter whether the facilities are located near each other or not.

X Undesirable. Locating a wedding department near one that uses flammable liquids would be an example of this category.”

Branch and Bound model

Branch and Bound method for exact solution

The method used for arriving at an optimal solution to the problem of quadratic Assignment is Branch and Bound.

- i. Lower Bound method
- ii. Upper Bound Method

UNIT-III

Introduction, material handling systems: selection, material handling principles, classification of material handling equipment, relationship of material handling to plant layout.

INTRODUCTION TO MATERIAL HANDLING SYSTEM

Haynes defines “Material handling covers the basic operations in connection with the movement of bulk, packaged and individual products in a semi-solid or solid state by means of gravity manually or power-actuated equipment and within the limits of individual producing, fabricating, processing or service establishment”. Material handling does not add any value to the product but adds to the cost of the product and hence it will cost the customer more. So the handling should be kept at minimum. Material handling in Indian industries accounts for nearly 40% of the cost of production. Out of the total time spent for manufacturing a product, 20% of the time is utilized for actual processing on them while the remaining 80% of the time is spent in moving from one place to another, waiting for the processing.

Materials handling can be also defined as ‘the function dealing with the preparation, placing and positioning of materials to facilitate their movement or storage. Material handling is the art and science involving the movement, handling and storage of materials during different stages of manufacturing. Thus the function includes every consideration of the product except the actual processing operation. Expressed in simple language, materials handling is loading, moving and unloading of materials. To do it safely and economically, different types of tackles, gadgets and equipment are used, when the materials handling is referred to as mechanical handling of materials. Since primitive men discovered the use of wheels and levers, they have been moving materials

mechanically. Any human activity involving materials need materials handling. However, in the field of engineering and technology, the term materials handling is used with reference to industrial activity. In any industry, be it big or small, involving manufacturing or construction type work, materials have to be handled as raw materials, intermediate goods or finished products from the point of receipt and storage of raw materials, through production processes and up to finished goods storage and dispatch points.

Materials' handling as such is not a production process and hence does not add to the value of the product. It also costs money; therefore it should be eliminated or at least reduced as much as possible. However, the important point in favour of materials handling is that it helps production. Depending on the weight, volume and throughput of materials, mechanical handling of materials may become unavoidable. In many cases, mechanical handling reduces the cost of manual handling of materials, where such material handling is highly desirable. All these facts indicate that the type and extent of use of materials handling should be carefully designed to suit the application and which becomes cost effective. Based on the need to be of optimum design and application specific to different type of industries, materials handling can be as diverse as industries them self. As a consequence, unfortunately, there is no universally accepted definition of materials handling. One of the definitions adopted way back by the American Materials Handling Society is: Materials handling is the art and science involving the moving, packaging and storing of substances in any form.

Some of the other definitions are:

- Materials handling is the movement and storage of materials at the lowest possible cost through the use of proper methods and equipment.

- Materials handling is the moving of materials or product by any means, including storage, and all movements except processing operations and inspection.
- Materials handling is the art and science of conveying, elevating, positioning, transporting, packaging and storing of materials.

There are other definitions also, but above few jointly bring out the salient features of materials handling. It is referred to as an art and science because to most of the materials handling problem no unique solution exists and more than one solution may be prescribed. Lot of subjective considerations of the materials handling engineer go into it. At the same time many scientific factors are also considered to arrive at the solution. In one of the definitions, all the functions of materials handling have been referred to which are conveying, elevating, positioning, transporting, packaging and storing. Storage or warehousing is very much a part of materials handling. Materials handling uses different equipment and mechanisms called Materials Handling Equipment. Though in one of the definitions, processing operations and inspection have been specifically excluded from scope of materials handling operations, it is worth mentioning that in specific cases processing or inspection of materials may be accomplished simultaneously with handling activity. One definition also covers the important objective of materials handling which is lowest cost solution.

Objectives of Material Handling

1. Minimize cost of material handling.
2. Minimize delays and interruptions by making available the materials at the point of use at right quantity and at right time.
3. Increase the productive capacity of the production facilities by effective utilization of capacity and enhancing productivity.

4. Safety in material handling through improvement in working condition.
5. Maximum utilization of material handling equipment.
6. Prevention of damages to materials.
7. Lower investment in process inventory.

Principles of Material Handling

Following are the principles of material handling:

1. **Planning principle:** All handling activities should be planned.
2. **Systems principle:** Plan a system integrating as many handling activities as possible and coordinating the full scope of operations (receiving, storage, production, inspection, packing, warehousing, supply and transportation).
3. **Space utilization principle:** Make optimum use of cubic space.
4. **Unit load principle:** Increase quantity, size, weight of load handled.
5. **Gravity principle:** Utilize gravity to move a material wherever practicable.
6. **Material flow principle:** Plan an operation sequence and equipment arrangement to optimize material flow.
7. **Simplification principle:** Reduce combine or eliminate unnecessary movement and/or equipment.
8. **Safety principle:** Provide for safe handling methods and equipment.
9. **Mechanization principle:** Use mechanical or automated material handling Equipment.
10. **Standardization principle:** Standardize method, types, size of material handling equipment.
11. **Flexibility principle:** Use methods and equipment that can perform a variety of task and applications.
12. **Equipment selection principle:** Consider all aspect of material, move and Method to be utilized.

13. **Dead weight principle:** Reduce the ratio of dead weight to pay load in mobile equipment.
14. **Motion principle:** Equipment designed to transport material should be kept in motion.
15. **Idle time principle:** Reduce idle time/unproductive time of both MH equipment and man power.
16. **Maintenance principle:** Plan for preventive maintenance or scheduled repair of all handling equipment.
17. **Obsolescence principle:** Replace obsolete handling methods/equipment when more efficient method/equipment will improve operation.
18. **Capacity principle:** Use handling equipment to help achieve its full capacity.
19. **Control principle:** Use material handling equipment to improve production control, inventory control and other handling.
20. **Performance principle:** Determine efficiency of handling performance in terms of cost per unit handled which is the primary criterion.

Material Handling Equipments

Broadly material handling equipment's can be classified into two categories, namely:

- (a) Fixed path equipments,
- (b) Variable path equipments.

Fixed path equipments: which move in a fixed path. Conveyors, monorail devices, chutes and pulley drive equipments belong to this category. A slight variation in this category is provided by the overhead crane, which though restricted, can move materials in any manner within a restricted area by virtue of its design. Overhead cranes have a very good range in terms of hauling

tonnage and are used for handling bulky raw materials, stacking and at times palletizing.

Variable path equipments: Which have no restrictions in the direction of movement although their size is a factor to be given due consideration trucks, forklifts mobile cranes and industrial tractors belong to this category. Forklifts are available in many ranges, they are manoeuvrable and various attachments are provided to increase their versatility.

Material Handling Equipments may be classified in five major categories.

1 Conveyors

Conveyors are useful for moving material between two fixed workstations, either continuously or intermittently. They are mainly used for continuous or mass production operations—indeed, they are suitable for most operations where the flow is more or less steady. Conveyors may be of various types, with rollers, wheels or belts to help move the material along: these may be power-driven or may roll freely. The decision to provide with care, since they are usually costly to install; moreover, they are less flexible and, where two or more converge, it is necessary to coordinate the speeds at which the two conveyors move.

2 Industrial Trucks

Industrial trucks are more flexible in use than conveyors since they can move between various points and are not permanently fixed in one place. They are, therefore, most suitable for intermittent production and for handling various sizes and shapes of material. There are many types of truck petrol- driven, electric, hand-powered, and so on. Their greatest advantage lies in the wide

range of attachments available; these increase the trucks ability to handle various types and shapes of material.

3. Cranes and Hoists

The major advantage of cranes and hoists is that they can move heavy materials through overhead space. However, they can usually serve only a limited area. Here again, there are several types of crane and hoist, and within each type there are various loading capacities. Cranes and hoists may be used both for intermittent and for continuous production.

4. Containers

These are either „dead containers (e.g. Cartons, barrels, skids, pallets) which Hold the material to be transported but do not move themselves, or liver containers (e.g. wagons, wheelbarrows or computer self-driven containers). Handling equipments of this kind can both contain and move the material, and is usually operated manually.

5. Robots

Many types of robot exist. They vary in size, and in function and manoeuvrability. While many robots are used for handling and transporting material, others are used to perform operations such as welding or spray painting. An advantage of robots is that they can perform in a hostile environment such as unhealthy conditions or carry on arduous tasks such as the repetitive movement of heavy materials.

The choice of material-handling equipment among the various possibilities that exist is not easy. In several cases the same material may be handled by various types of equipments, and the great diversity of equipment and attachments available does not make the problem any easier. In several cases, however, the nature of the material to be handled narrows the choice.

Some of the materials handling equipment are shown in Below

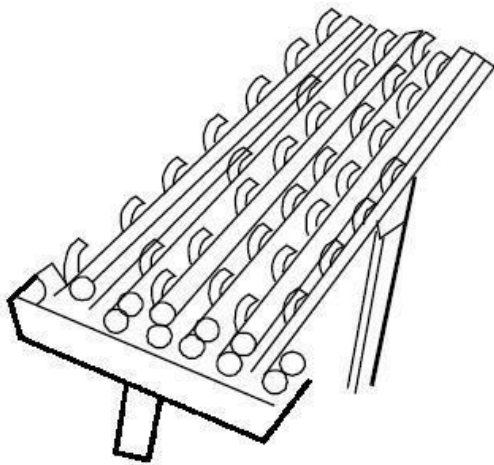

Wheel conveyor

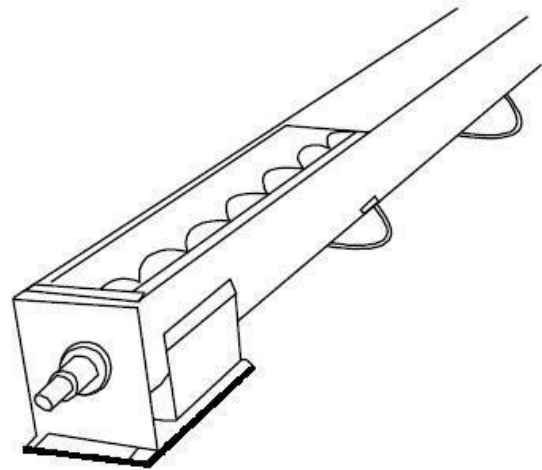

Screw conveyor

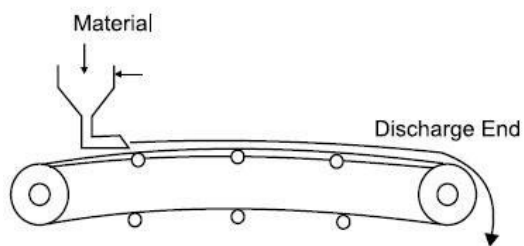

Belt conveyor

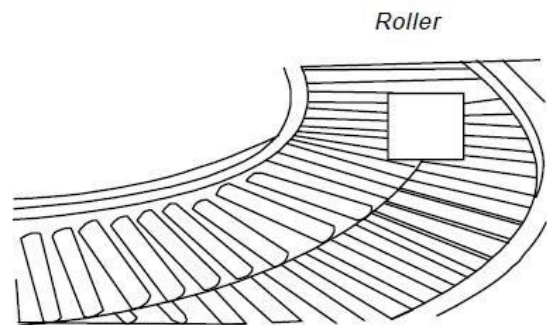

Roller conveyor

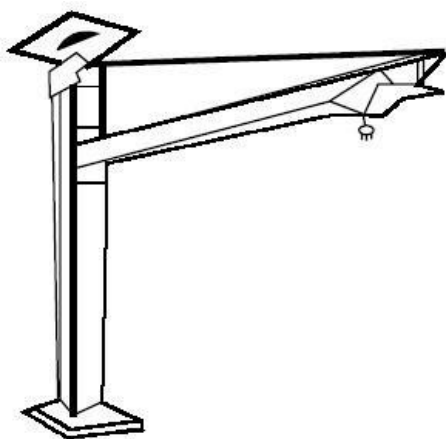

Jib crane

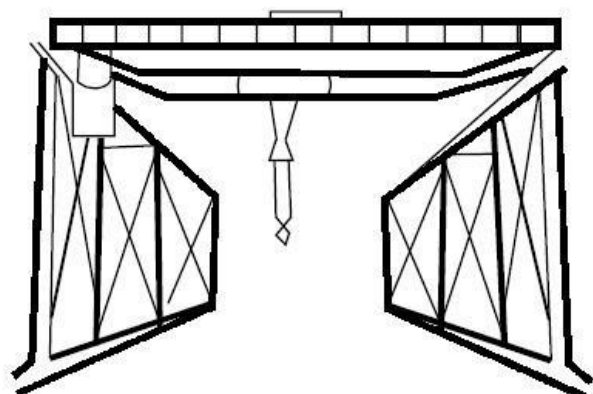

Bridge crane

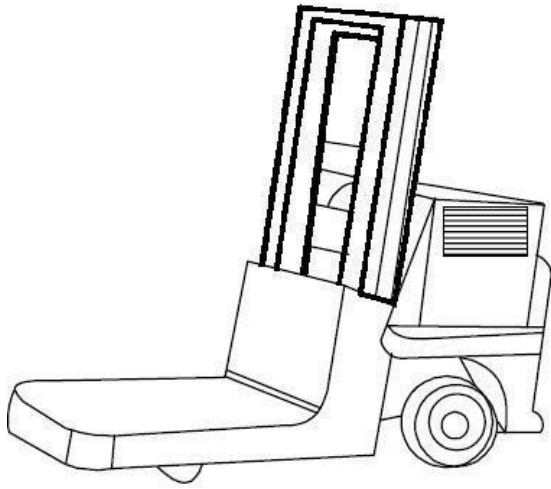

Platform truck

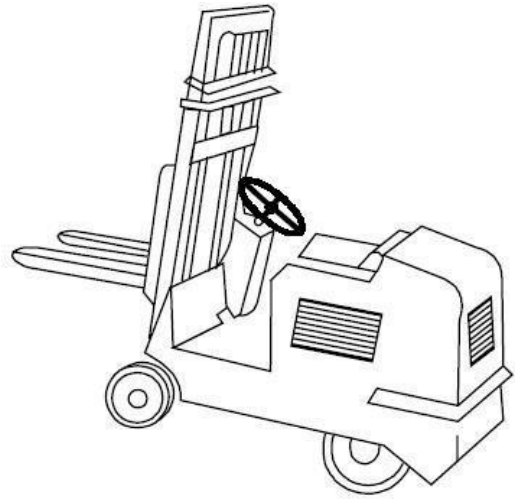

Forktruck

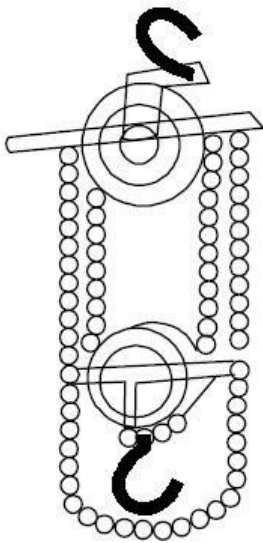

Chain hoist

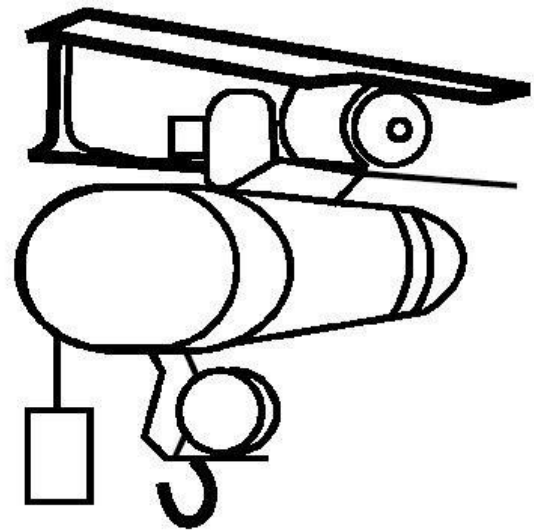

Electric hoist

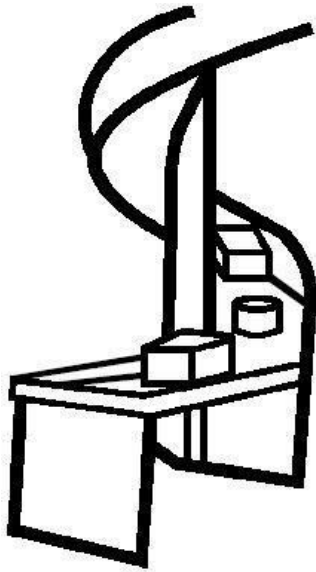
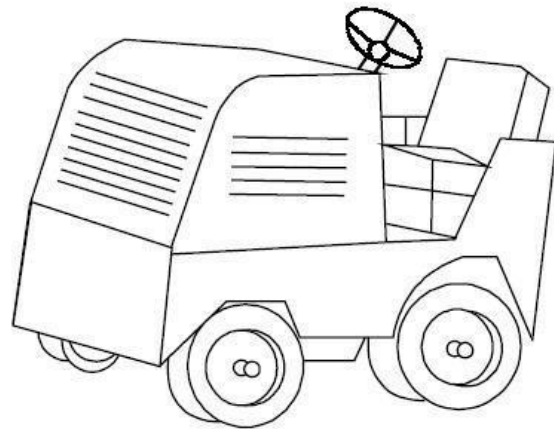
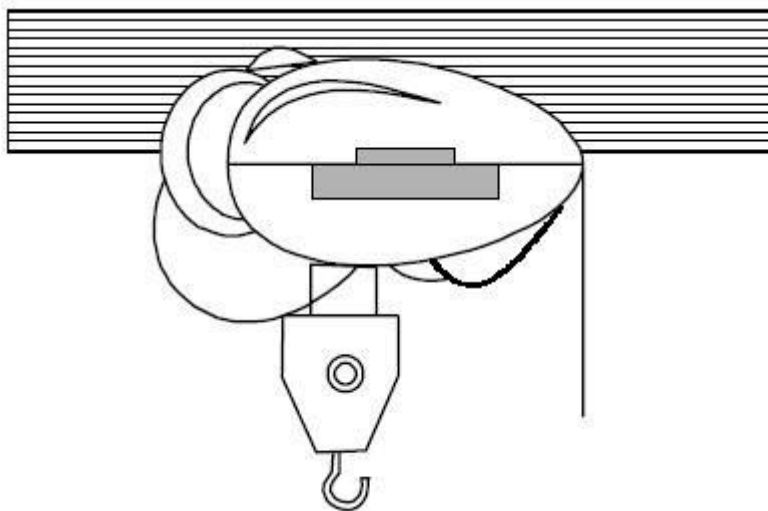
**Spiral chute****Industrial tractor****Electrical hoist**

Relationship between Plant Layout and Material Handling

The production efficiency of a manufacturing unit depends on how well various machines, flow paths, storage facilities, and employee amenities are located in the plant. A systematically designed plant can ensure the smooth and rapid movement of material, from the raw material stage to the end product

stage. Plant layout encompasses new layout as well as improvement in the existing layout.

In modern manufacturing facilities, efficient layout is complemented by world class material handling equipment to drive the overall efficiency. Some of the issues that warrant careful layout planning and utilizing material handling equipments are improper material flow paths resulting in production idle time, production bottlenecks due to improper facility layout and planning, increased material handling costs due to increased number of "touches" across different operations, inability to scale up operations due to poorly designed infrastructure and material flow patterns, and reduced employee morale due to non availability of adequate amenities across the facility.

There is a close relationship between plant layout and material handling. A good layout ensures minimum material handling and eliminates re handling in the following ways:

1. Material movement does not add any value to the product so, the material handling should be kept at minimum though not avoid it. This is possible only through the systematic plant layout. Thus a good layout minimizes handling.
2. The productive time of workers will go without production if they are required to travel long distance to get the material tools, etc. Thus a good layout ensures minimum travel for workman thus enhancing the production time and eliminating the hunting time and travelling time.
3. Space is an important criterion. Plant layout integrates all the movements of men, material through a well designed layout with material handling system.
4. Good plant layout helps in building efficient material handling system. It helps to keep material handling shorter, faster and economical.

A good layout reduces the material backtracking, unnecessary workmen movement ensuring effectiveness in manufacturing. Thus a good layout always ensures minimum material handling

The essential requirements of a good materials handling system may be summarized as:

- (i) Efficient and safe movement of materials to the desired place.
- (ii) Timely movement of the materials when needed.
- (iii) Supply of materials at the desired rate.
- (iv) Storing of materials utilising minimum space.
- (v) Lowest cost solution to the materials handling activities.

Overview of Material Handling

Material handling (MH) involves “short-distance movement that usually takes place within the confines of a building such as a plant or a warehouse and between a building and a transportation agency.”

1 It can be used to create “time and place utility” through the handling, storage, and control of material, as distinct from manufacturing (i.e., fabrication and assembly operations), which creates “form utility” by changing the shape, form, and makeup of material.

2 It is often said that MH only adds to the cost of a product, it does not add to the value of a product. Although MH does not provide a product with form utility, the time and place utility provided by MH can add real value to a product, i.e., the value of a product can increase after MH has taken place;

for example:

- The value (to the customer) added by the overnight delivery of a package (e.g., Federal Express) is greater than or equal to the additional cost of the service as compared to regular mail service—otherwise regular mail would have been used.

- The value added by having parts stored next to a bottleneck machine is the savings associated with the increase in machine utilization minus the cost of storing the parts at the machine

Principles of Material Handling

Although there are no definite “rules” that can be followed when designing an effective MHS, the following “Ten Principles of Material Handling,”³ as compiled by the College-Industry Council on Material Handling Education (CIC-MHE) in cooperation with the Material Handling Institute (MHI), represent the distillation of many years of accumulated experience and knowledge of many practitioners and students of material handling:

1. Planning Principle. All MH should be the result of a deliberate plan where the needs, performance objectives, and functional specification of the proposed methods are completely defined at the outset.

2. Standardization Principle. MH methods, equipment, controls and software should be standardized within the limits of achieving overall performance objectives and without sacrificing needed flexibility, modularity, and throughput.

3. Work Principle. MH work (defined as material flow multiplied by the distance moved) should be minimized without sacrificing productivity or the level of service required of the operation.

4. Ergonomic Principle. Human capabilities and limitations must be recognized and respected in the design of MH tasks and equipment to ensure safe and effective operations.

5. Unit Load Principle. Unit loads shall be appropriately sized and configured in a way that achieves the material flow and inventory objectives at each stage in the supply chain.

6. Space Utilization Principle. Effective and efficient use must be made of all available (cubic) space.

7. System Principle. Material movement and storage activities should be fully integrated to form a coordinated, operational system which spans receiving, inspection, storage, production, assembly, packaging, unitizing, order selection, shipping, and transportation, and the handling of returns.

8. Automation Principle. MH operations should be mechanized and/or automated where feasible to improve operational efficiency, increase responsiveness, improve consistency and predictability, decrease operating costs, and to eliminate repetitive or potentially unsafe manual labour.

9. Environmental Principle. Environmental impact and energy consumption should be considered as criteria when designing or selecting alternative equipment and MHS.

10. Life Cycle Cost Principle. A thorough economic analysis should account for the entire life cycle of all MHE and resulting systems.

UNIT-IV

Basic material handling systems: Selection, Material handling method – path, Equipment, Function orientated systems

Selection of Material Handling equipment is an important decision as it affects both cost and efficiency of handling system. The following factors are to be taken into account while selecting material handling equipment.

Properties of the Material

Whether it is solid, liquid or gas, and in what size, shape and weight it is to be transported are the main factors to be taken into consideration and can lead to a preliminary elimination from the range of available equipment under review. If a material is fragile, corrosive or toxic this will imply that certain handling methods and containers will be preferable to others.

Layout and characteristics of the building

Another limiting factor is the convenience of space for handling. Low-level ceiling may exclude the use of hoists or cranes, and the presence of supporting columns in difficult places can restrict the size of the material-handling equipment. If the building is multi-storied, chutes or ramps for industrial trucks may be used. Layout itself will indicate the type of production operation (continuous, intermittent, fixed position or group) and can suggest some items of equipment that will be more proper than others. Floor capacity also aids in selecting the best material handling equipment.

Production Flow

If the flow is properly constant between two immovable positions, fixed equipment such as conveyors or chutes can be effectively used. If, the flow is not continuous and the direction changes rarely from one point to another

because several products are being produced simultaneously, moving equipment such as trucks would be desirable.

Cost considerations

The previous factors can help to limit the range of suitable equipment, while costing can help in taking a final decision. Several cost features need to be taken into consideration, when the comparisons are made between several items of equipment that are capable of handling the same load. Initial investment and operating and maintenance costs are the major cost to be measured. By comparing the total cost for each of the items of equipment, a more rational decision can be made on the most appropriate choice.

Nature of Operations

Equipment Selection also depends on mode of operations like whether handling is temporary or permanent, whether the flow is continuous or discontinuous and material flow pattern-vertical or horizontal.

Engineering Factors

Selection of equipment also depends on engineering factors like door and ceiling dimensions, floor space, floor conditions and structural strength.

Equipment Reliability

Reliability of the equipment and supplier reputation and the after sale service also plays an important role in selecting material handling equipment.

Importance of Materials Handling

The importance of materials handling is that it helps productivity and increases profitability. Many enterprises go out of business because of

inefficient materials handling practices. In many cases it is seen that rival industries are using same or similar production equipment, and one who uses improved materials handling system stays forward of their competitors. A well designed materials handling system attempts to achieve the following:

Improve efficiency of a production system by ensuring the right quantity of materials delivered at the right place at the right time most economically.

- Cut down indirect labour cost.
- Reduce damage of materials during storage and movement.
- Maximize space utilization by proper storage of materials and thereby reduce storage and handling cost.
- Minimize accident during materials handling.
- Reduce overall cost by improving materials handling.
- Improve customer services by supplying materials in a manner convenient for handling.
- Increase efficiency and scalability of plant and equipment with integral materials handling features

Apart from these, for certain industries, like process industries, heavy manufacturing industries, construction industries, mining industries, and shipbuilding or aircraft industries etc., the materials are so large and heavy that these industries just cannot run without appropriate materials handling system.

All the above points clearly portray the importance of materials handling in an industry or a material transportation system. However, the negative aspects of materials handling should also not be overlooked. These are:

Additional capital cost involved in any materials handling system.

Once a materials handling system get implemented, flexibility for further changes gets greatly reduced.

With an integrated materials handling system installed, failure/stoppage in any portion of it leads to increased downtime of the production system.

Materials handling system needs maintenance, hence any addition to materials handling means additional maintenance facilities and costs.

Systems Concept

In the previous sections materials handling have already been referred to as a system and it will be repeated many times in future. It is, therefore, important to understand the systems concept of materials handling. The term “system” has many senses depending on the field where used. A general definition of the term could be: a complex unity formed of many often diverse parts subject to a common plan or serving a common purpose. The important characteristics of a system are that the parts, called subsystems, are interrelated and guided by an purpose for which the system exists. In an industry, materials handling is a subsystem (or part) of the production system. Materials handling can be reflected to be a system whose subsystems are:

Design or method to be adopted,

Types of materials handling equipment to be used,

Different operations like packing /unpacking, movement and storage involved,

Maintenance required for the equipment employed,

Mode of transportation by the raw materials suppliers, distributors / customers, waste / scrap collectors etc. The common objective by which the different subsystems are guided is the lowest cost solution of the materials handling system.

In actual exercise, the system concept of materials handling means the different types of materials handling needed at different parts of an industry and associated suppliers' and customers' end are to be considered in whole. Only this methodology will ensure an overall cost effective materials handling solution for the industry.

A handling engineer could think about the handling downside of a specific space as a personal, isolated case and produces the solution. He could have made the foremost economic solution for that downside alone; however it should not cause the lowest price answer for the complete plant. There were several industries in United Nations agency area unit persecution which were over hundred sizes of containers/boxes at intervals constant plant! This can be the results of determination handling issues of various areas in isolation. From systems purpose of read, the handling downside of a plant at the side of its associated suppliers' and customers' issues ought to be thought of together system and therefore the subsystems got to be designed and operated consequently. This systems construct may be a logical approach which may bring home the bacon the target of any handling theme that is lowest price answer.

Five major types of materials handling methods

- Movement - Involves the actual transportation or transfer of material from one point to the next.
- Quantity - Dictates the type and nature of the material handling equipment and also cost per unit for the conveyance of the goods.
- Time - How quickly the material can move through the facility Space - concerned with the required space for the storage of the material handling equipment and their movement, as well as the queuing or staging space for the material itself.

- Control - Racking of the material, positive identification, and inventory management. A major competitive advantage due to its impact on quality, cost, productivity, inventory, and response time; in total a revenue enhancer not a cost contributor.

Advantages of correct materials handling

- Savings in storage and operating space
- Better stock control
- Improved working conditions
- Improved quality
- Lower risk of accidents
- Reduced processing time
- Lower production costs
- Less waste of time and materials
- In order to perform the activities of materials handling the basic goal is to minimize the production costs. This general objective can be further subdivided into specific objectives as follows:
 - To reduce the costs by decreasing inventories, minimizing the distance to be handled and increasing productivity.
 - To increase the production capacity by smoothing the work flow,
 - To minimize the waste during handling.
 - To improve distribution through better location of facilities and improved routing.
 - To increase the equipment and space utilization.
 - To improve the working conditions.
 - To improve the customer service.
- Basic Materials Handling Systems
- The different material handling systems can be classified according to the type of equipment used, material handled, method used or the function

performed. Equipment-Oriented Systems: Depending upon the type of equipment used, there are several systems.

- Overhead systems
- Conveyer systems
- Tractor-tailor system
- Fork-life truck and pallet system
- Industrial truck systems
- Underground systems
- Material Oriented Systems:
 - These may be of the following types:
 - Unit handling systems
 - Bulk handling systems
 - Liquid handling systems
 - A unit load consists of a number of items so arranged that it can be picked up and moved as a single entity such as a box, bale, roll etc. Such a system is more flexible and requires less investment.

Method Oriented Systems

According to the method of handling and method of production, the material handling systems can be:

- Manual systems
- Mechanized or automated systems
- Job-shop handling systems, or
- Mass-production handling systems
- Function Oriented Systems:
 - The systems can be defined according to the material handling function performed as follows:
 - Transportation systems

- Conveying systems
- Transferring systems
- Elevating systems

Selection and Design of Handling System:

The selection and design of the material system should be done alongside the development of the layout as each one affects each other. Hence, an integrated approach to the design process is usable. A computerized technique known as COFAC (Computerized Facilities Design) has been developed for integrated handling system and layout design. The steps to be followed in the

selection and design of handling systems are as follows:

- Identification of system
- Review of design criteria and objectives of the handling system
- Data collection regarding flow pattern and flow requirements
- Identification of activity relationships
- Determining space requirement and establishing material flow pattern
- Analysis of material and building characteristics
- Preliminary selection of basic handling system and generation alternatives considering feasibility of mechanization and equipment capabilities
- Evaluation of alternatives with respect to optimal material flow, utilizing gravity, minimum cost, flexibility, ease of maintenance, capacity utilization and other objectives of the system design considering various tangible and intangible factors
- Selection of the best suited alternative and checking it for compatibility
- Specification of the system

- Procurement of the equipment and implementation of the system

Factors Affecting the selection of Materials Handling Equipment

The selection of materials handling equipment requires the attaining of proper balance between the production problem, the capabilities of the equipment available, and the human element involved. The ultimate aim is to arrive at the lowest cost per unit of material handled.

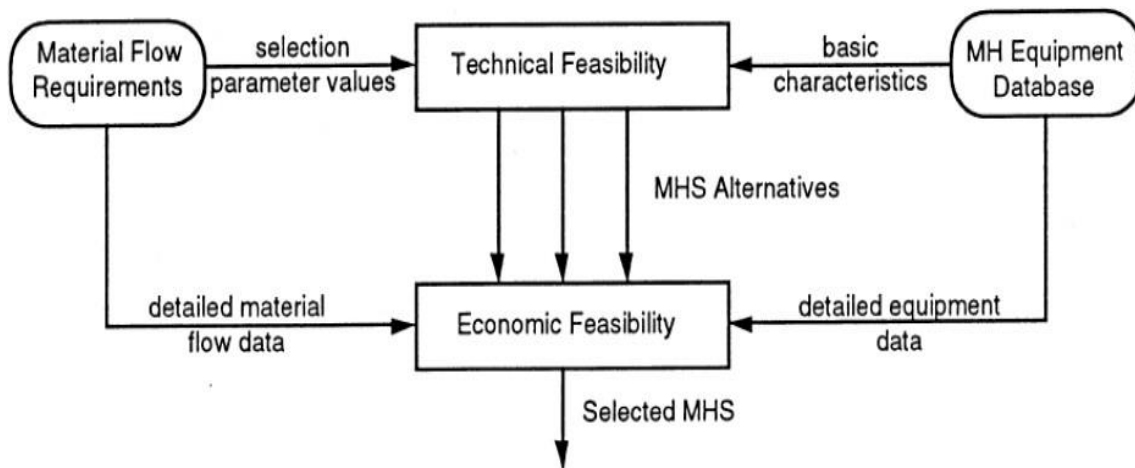

MHE selections

Equipment factors to be taken into consideration may well include the following:

Adaptability: the load carrying and movement characteristics of the equipment should fit the materials handling problem.

Flexibility: Where possible the equipment should have flexibility to handle more than one material, referring either to class or size.

Load capacity: Equipment selected should have great enough load-carrying characteristics to do the job effectively, yet should not be too large and result in excessive operating costs.

Power: Enough power should be available to do the job.

Speed: Rapidity of movement of material, within the limits of the production process or plant safety, should be considered. **Space requirements:** The space required to install or operate materials handling equipment is an important factor in its selection.

Supervision required: As applied to equipment selection, this refers to the degree of automaticity designed into the equipment. **Ease of maintenance:** Equipment selected should be easily maintained at reasonable cost.

Environment: Equipment selected must conform to any environment regulations.

Cost: The consideration of the cost of the equipment is an obvious factor in its selection.

Material handling equipment:

- It involves the movement of materials, manually or mechanically within the plant it is a mechanical device for handling of supplies in the greater ease and economy.
- The movement may be horizontal, vertical or combination of both.
- MHE refers to various materials handling equipments like carts, hand trucks, false lifts, conveyers and also not limited to self pictures, motorized pullet jacks, track and other specialized industrial tracks powered by electric motors internal combination engine. **Need for maintenance of material handling equipment:**
- It eases the usage of manual handling and enhances operational efficiency.
- In today's economic climate of high labour and capital equipment cost, unexpected machine failures and malfunctions can seriously and relatively impact company profits.

- The breakdown, failure or malfunction of material handling equipment can cost a company time and money
- material handling maintenance program for MHE will help to maintain the high efficiency and keep it in running condition
- This also reduce the cost of expensive repairs as a result of a breakdown or unnecessary wear, enhanced productivity due to lease machinery downtime and reduction in the potential for personal injury Maintenance of material handling

UNIT-V

Methods to minimize cost of material handling- Maintenance of material handling equipments, safety in handling ergonomics of material handling equipment. Design, miscellaneous equipments.

Introduction and Importance

Material handling is a necessary and significant component of any productive activity. It is something that goes on in every plant all the time. Material handling means providing the right amount of the right material, in the right condition, at the right place, at the right time, in the right position and for the right cost, by using the right method. It is simply picking up, moving, and lying down of materials through manufacture. It applies to the movement of raw materials, parts in process, finished goods, packing materials, and disposal of scraps. In general, hundreds and thousands tons of materials are handled daily requiring the use of large amount of manpower while the movement of materials takes place from one processing area to another or from one department to another department of the plant. The cost of material handling contributes significantly to the total cost of manufacturing.

In the modern era of competition, this has acquired greater importance due to growing need for reducing the manufacturing cost. The importance of material handling function is greater in those industries where the ratio of handling cost to the processing cost is large. Today material handling is rightly considered as one of the most potentially lucrative areas for reduction of costs. A properly designed and integrated material handling system provides tremendous cost saving opportunities and customer services improvement potential.

Objectives of Material Handling

The primary objective of a material handling system is to reduce the unit cost of Production.

The other subordinate objectives are:

1. Reduce manufacturing cycle time
2. Reduce delays, and damage
3. Promote safety and improve working conditions
4. Maintain or improve product quality
5. Promote productivity
 - i. Material should flow in a straight line
 - ii. Material should move as short a distance as possible
 - iii. Use gravity
 - iv. Move more material at one time
 - v. Automate material handling
6. Promote increased use of facilities
 - i. Promote the use of building cube
 - ii. Purchase versatile equipment
 - iii. Develop a preventive maintenance program
 - iv. Maximize the equipment utilization etc.
7. Reduce tare weight

8. Control inventory

Reduce Cost of Handling

The total cost of material handling per unit must decrease. The total cost per unit is the sum of the following:

1. Cost of material handling equipment – both fixed cost and operating cost

Calculated as the cost of equipment divided by the number of units of material Handled over the working life of the equipment.

2. Cost of labour – both direct and indirect associated cost calculated in terms of cost per unit of material handled.

3. Cost of maintenance of equipment, damages, lost orders and expediting expenses, also calculated, in terms of cost per unit of material handled.

Reduced Manufacturing Cycle Time

The total time required to make a product from the receipt of its raw material to the finished state can be reduced using an efficient and effective material handling system. The movement of the material can be faster and handling distance could be reduced with the adoption of an appropriate material handling system.

Limitations of Automated Material Handling Systems

A good management practice is to weigh benefits against the limitations or Disadvantages before contemplating any change. Material handling systems also have consequences that may be distinctly negative.

These are:

1. Additional investment
2. Lack of flexibility
3. Vulnerability to downtime whenever there is breakdown
4. Additional maintenance staff and cost
5. Cost of auxiliary equipment.
6. Space and other requirements:

The above limitations or drawbacks of adopting mechanized handling equipment have been identified not to discourage the use of modern handling equipment but to emphasize that a judicious balance of the total benefits and limitations is required before an economically sound decision is made.

Designing MH systems

As you have seen, to study the design of each of the categories mentioned above will take ages, and serve not much purpose. We take the example of the design of a conveyor based system, to get some idea of the METHODS that are useful in making design decisions.

Conveyors can be categorized in several different ways. On the basis of their conceptual layout, we use the following two categories:

(1) Open vs. Re-circulating.

Open conveyor systems have fixed material entry and exit points. Materials go across the system only once, and need to be carried back to the entry point and re-loaded if they need transportation across the system. Re-circulating conveyors form a closed loop, such that materials once loaded can travel on them forever.

(2) Uni-directional vs. Bidirectional.

Most conveyors operate uni-directionally, that is, at a given point on the conveyor, the materials can only travel in one direction. Some sophisticated conveyors (for example, the Bosch Flexible Assembly System in our Manufacturing Systems Lab) are bi-directional. Bi-directional conveyors are often modular in structure. Each module forms one segment of the conveyor, and can be individually switched to go forward or backward. Therefore these systems need some form of automatic control to managed proper material flow between stations in a shop. The figures below show schematics of typical uni-directional (that is, the conveyor cannot reverse its direction) conveyor systems.

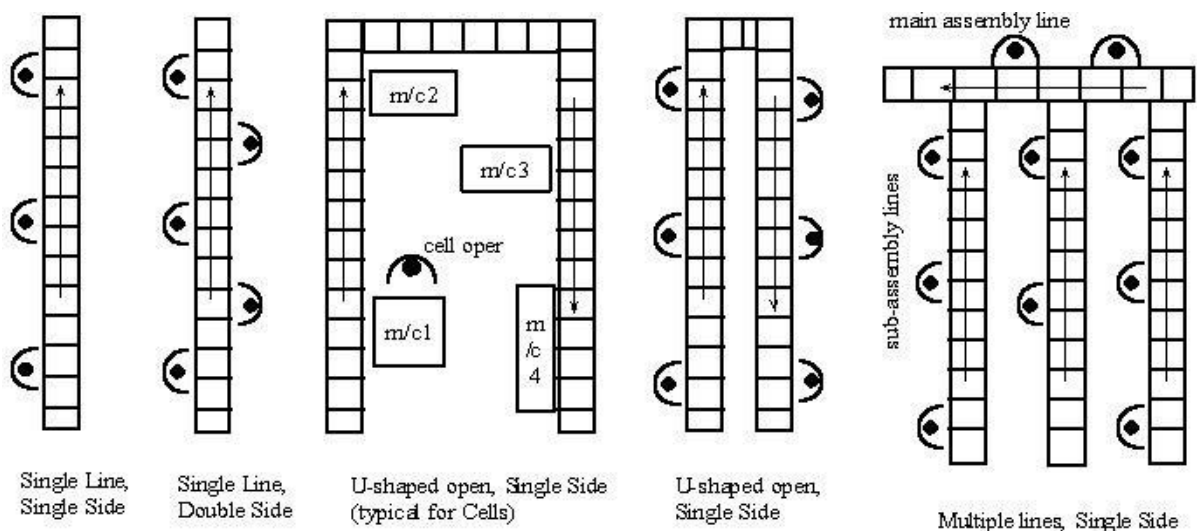

Typical applications

Open single lines: assembly lines, chemical plants, etching operations, for example to make lead-frames for electronics chips, etc. Double-sided open lines (these can fit more operators per unit length of conveyor): assembly lines. U-shaped open lines: typical for manufacturing cells. Notice that a cell may have fewer operators than the number of machines. U-shaped assembly lines (very compact, single loading and unloading point (often an advantage for material

handling): Assembly lines. Multiple Lines: typically used for a product with several sub-assembly operations. Each line performs a single module of the product, and the main line assembles the final product.

The following figure shows two basic types of re-circulating (closed loop) conveyors.

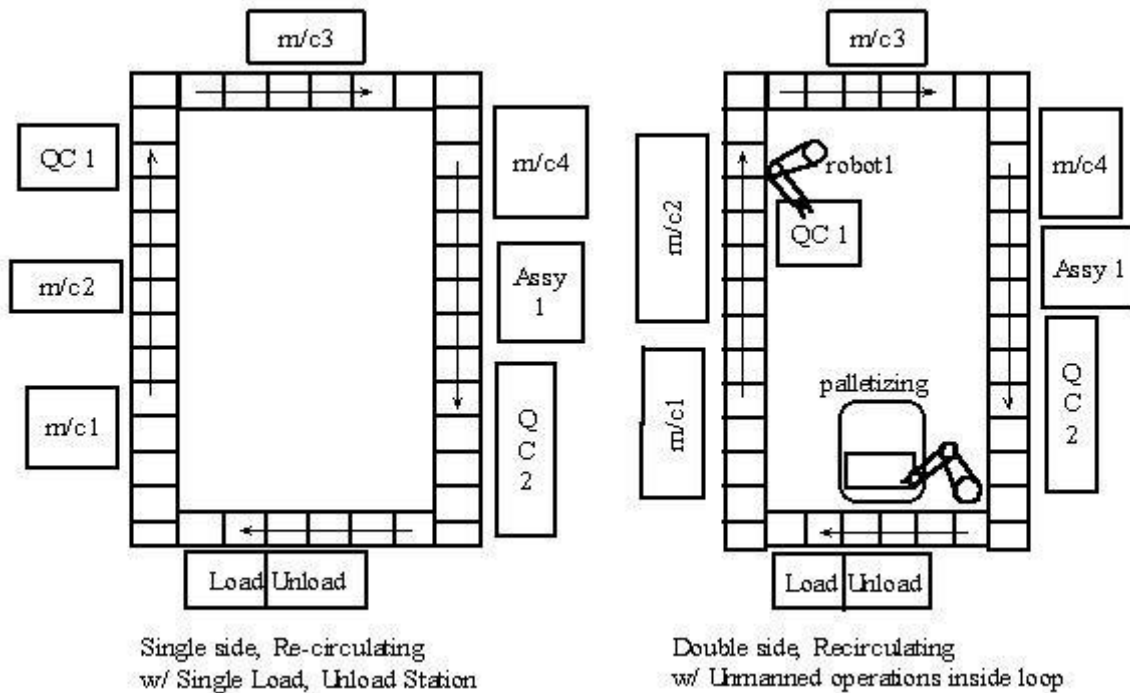

These are quite popular in several machining shops, and sometimes also in assembly shops. The nice feature is that jobs that cannot be directly worked upon can just remain on the conveyor. When the processor/machine becomes free, it just waits for the job to return and then picks it up and performs the operations necessary. Thus the conveyor also acts as a buffer. Another nice feature is that there is complete flexibility to place the loading and unloading stations at any point along such conveyors. There may be one or more of loading and unloading stations, or there may even be a common load/unload point. The shape of closed loop conveyors can be modified to meet the shape of the room/shop-floor, or to go around some large machines, etc. The most common shapes are rectangular, or semi-circular ended rectangles.

Quantitative models for conveyors: Once the conveyor type has been determined, its design requires determination of conveyor width, speed of operation, power requirements, length and shape. We now look at some simple methods and guidelines to determine some of these parameters.

The first set of guidelines of interest is attributed to T. T. Kwo. Kwo's guidelines for closed-loop, irreversible conveyors are:

1. Uniformity principle: Materials should be uniformly distributed over the length of the conveyor.
2. Capacity principle: The carrying capacity of the conveyor must equal or exceed the system throughput requirements.
3. Speed principle: the speed of the conveyor must be within the limits imposed by the capacity of the load/unload stations as well as the technical capabilities of the conveyor.

The shape of the conveyor is often determined by two factors:

- (1) Existing machines and their relative positions (which are typically determined by the sequence of operations on the parts ;)
- (2) Existing space and floor-plan of the shop floor.

The width of the conveyor is determined by the size of the part carriers. Usually, parts are kept on bins or carriers which travel above the conveyor. These carriers are usually rectangular. Their size is determined by two factors: the size of each part, and the number of parts being carried on each carrier. Given the size of the carrier, it is easy to determine the width of the conveyor. Typically, if it is important to retain a fixed orientation for each carrier, then it must travel in the direction along its longer side; thus the width of the conveyor is just greater than the shorter side of the carrier.

Length of the conveyor

Single Part per Carrier case (deterministic).

Let: Required loading speed = l parts/min

Conveyor length used by each carrier = d (= carrier length + allowance)

Number of unloading stations = M_u

Average unloading speed = μ parts/min

Conveyor velocity = v

If a carrier passes a free unloading station, it will be unloaded. If all unload stations are busy, the carrier will continue to recycle on the conveyor.

Condition 1. If units arrive at the loading station faster than they can be loaded, there will be blocking.

This condition occurs when: $l < v/d$

That is, one would set the conveyor velocity at a level such that the carrier arrival rate (v/d) is greater than the part arrival rate, l .

Condition 2. The unloading stations must be able to handle the conveyor traffic.

In short,

This means that $M_u \cdot \mu > l$.

Also note, that if $l \cdot d/v = 2/3$, then, in the steady state, every third carrier will be empty.

Therefore, an unloading station with unload times between d/v and $1.5d/v$ will have sufficient capacity. However, it will not be ready to unload every second consecutive part that arrives. In the steady state, there will be several filled, completed jobs always circulating on the conveyor.

Multiple parts per carrier case [Muth's model]:

Now we look at a more complex model, where each carrier can carry more than one units of material. As the carrier goes past a workstation, it may pick up a unit, and work on it. When the processing is completed, it will put the part down on the next carrier that comes to it, with some free space to load the material. Over a period of time, such systems operate in steady state, with a periodic nature.

If I stand at station-R, and look at the situation, it will load R_1 parts on the first carrier going past it; it will load R_2 parts on the next one; R_3 on the third, and so on. Then, after P carriers go past, it will repeat this cycle

of loading $R_1 \dots R_2 \dots R_3 \dots R_P$ parts. Of course, R_i can be positive (loading), or negative

(Unloading).

Muth's model for this situation is discussed below:

Number of stations around the conveyor = S

Number of carriers on the conveyor = K

Number of parts picked/placed by Station i on the n -th carrier = $f_i(n)$

If $f_i(n)$ is +ve, parts were loaded, if -ve, they were unloaded.

Each station will pick/place a constant number of parts from every p -th carrier passing in front of them:

$f_i(n) = f_i(n + p)$, for each i .

Note: p is called the periodicity of the system. In steady state, there should be no build-up of material in the shop \Rightarrow The sum of all material loaded/unloaded from all carriers = 0.

Ergonomics: The branch of engineering science in which biological science is used to study the relation between workers and their environments.

The word Ergonomics has its origin in two Greek words Ergon meaning laws. So it is the study of the man in relation to his work. In USA and other countries it is called by the name human engineering or human factors engineering. ILO defines human engineering as, —The application of human biological sciences along with engineering sciences to achieve optimum mutual adjustment of men and his work, the benefits being measured in terms of human efficiency and well-being. The human factors or human engineering is concerned with man-machine system. Thus another definition which highlights the man-machine system is: —The design of human tasks, man-machine system, and effective accomplishment of the job, including displays for presenting information to human sensors, controls for human operations and complex man-machine systems.

Human engineering focuses on human beings and their interaction with facilities and environments used in the work. Human engineering seeks people use and the environment in which they use the things to match capabilities, limitations and needs of people. products, equipment to change the things in a better way the

—Ergonomics is the science of studying people at work and then designing tasks, jobs, information, tools, equipment, facilities and the working environment so people can be safe and healthy, effective, productive and comfortable.

Human engineering (ergonomics) has two broader objectives:

1. To enhance the efficiency and effectiveness with which the activities (work) is carried out so as to increase the convenience of use, reduced errors and increase in productivity.

2. To enhance certain desirable human values including safety reduced stress and fatigue and improved quality of life.

Thus, in general the scope and objective of ergonomics is —designing for human use and optimizing working and living conditions. Thus human factors (ergonomics) discover and apply information about human behavior. Abilities and limitations and other characteristics to the design of tools, machines, systems, tasks, jobs and environment for productive, safe, comfortable and effective human use. Ergonomics aims at providing comfort and improved working conditions so as to channelize the energy, skills of the workers into constructive productive work. This accounts for increased productivity, safety and reduces the fatigue. This helps to increase the plant utilization.

Elements of a Material Handling Ergonomics Program

Analyze management operations

We must first recognize that materials handling is often one of the largest cost components of a product, operation or service. Unnecessary handling of materials costs time and money.

We must understand the relationship between workstation design and the jobs workers are expected to perform. People responsible for designing work methods must pay particular attention to details of the task involved to ensure the greatest possible harmony between the work method and the worker.

Make purchasing agents an important part of the materials handling program. Have them pay attention to details, such as size, weight, packaging and convenience for handling. Use sold to/ship to arrangements to eliminate in-plant handling wherever possible.

Products being shipped to your company for distribution may be more efficiently transported from your supplier to the customer, saving freight and

handling. Reduce overall work-in-process quantities. Failure to do so often result in overcrowding problems— extra handling, use of larger containers or parts stacked higher.

Housekeeping problems may develop, increasing possibilities of materials handling vehicle accidents and damage to materials and finished goods. To reduce work-in process quantities, it is necessary to tighten controls and shorten forecasting for inventory, scheduling, ordering and shipping.

Manufacture products on an as ordered basis, instead of stockpiling for anticipated use. Perform product analysis. Changes in the product sometimes result in reduced materials handling. Consider lightening the product, and allowing a worker or conveyor to handle more pieces at one time. Plan to expand or change. Production usually suffers under crowded conditions. Much of this material is dependent upon management's policies and procedures.

But even in the absence of management analysis, you personally can analyze and implement change in the following ways. Establish disposal and storage methods, and ways to improve material flow for scrap, waste materials, containers, tools and equipment. Each workstation must be analyzed.

Material flow

It is usually not enough to simply observe and study a specific manual materials handling task. Key questions arise regarding how the material is routed through the facility or work site that can only be answered by looking at the bigger picture.

Eliminate unnecessary materials handling by combining operations or shortening the distances that the materials must be moved. Look for crossing paths, loops, backtracking and a lack of direction during production. One benefit of short distances is the ability to link workstations by conveyors and

reduce carrying distances. Also, less mechanical handling can mean fewer opportunities for forklift accidents. Walk through your operations with an employee. Make immediate simple changes. (Make written suggestions for observed cost-saving and people-saving changes that need approval or further evaluation.) Simplify, rearrange or change the process. Often, processes that are handled differently can be performed in a similar fashion to simplify the material flow. Plan adequate aisles for intended material flow, and emergency access and exit. Personnel must be able to evacuate quickly in an emergency. Cramped aisle ways may restrict exits and cause panic. Emergency vehicles also must be able to quickly gain access. Adequate aisle ways and exits facilitate the orderly movement of materials. Avoid the necessity of working in aisle ways.

Workplace

Check floor surfaces. Repair cracks, depressions, holes, damaged flooring and surfaces.

Starting forces for carts can double or triple on poor surfaces. Worn-out or damaged wheels also can increase the required force.

Insist on good housekeeping. Keep floor surfaces clean. Water, oil, grease and material scrap reduce traction and increase the force required to push or pull carts. Poor housekeeping only increases materials handling obstacles.

Review plant design to remove building obstructions that interfere with materials handling.

In materials handling, —what goes down must come up. To prevent repeated stooping and bending, the goal is to bring both incoming and outgoing materials at each process to a suitable work height. We recommend at least a minimum of 20 inches from the floor, but ideally to knuckle height of about 30 inches. Reduce the need to raise or lower materials from above shoulder height. If you

must raise or lower materials above shoulder height, store lighter objects on top shelves.

Remove constraints that prevent materials from being positioned close to the body. Allow enough space for feet to get under tables and conveyor belts. Provide clear access to shelves and adequate space around pallets.

Reduce height differences during load travel. Keep loads between knuckle and shoulder height from origin to destination. Slide objects rather than lifting and lowering them.

Provide adjustable chairs for all operations. Chairs should swivel for side-lifting, whether they are located in the company president's office or on the small-parts assembly line. Load Guidance Some specific considerations when handling loads would include:

- Small is better than big.

Generally speaking, when it comes to the manual handling of loads, small is better than big. Large, awkward loads present the handler with a variety of potential problems including added stress and strain to the upper extremities and the back. Containers should not be so tall that they obstruct vision or, conversely, bump annoyingly against the legs as they are carried. Loads that

Plant Layout and Material Handling will be lifted should be packaged in containers narrow enough to fit between the knees during a squat lift (knees and hips bent, and the back more or less straight). This design will allow the load to be positioned close to the spine, thereby reducing the load's compressive forces on the spine.

- Loads should not be too light.

Loads that are too light may encourage the handler to lift a number of units at a time, creating an unstable load that is more likely to fall. Conversely, loads should sometimes be made so heavy that people will not attempt to lift the load without the help of another person or will get mechanical assistance. Whenever possible, packages should be labelled with the content's weight so people who handle them will immediately know how heavy a load they are dealing with.

- Containers should be designed to prevent their contents from shifting.

Loads that shift in their containers may move the centre of gravity away from the handler, suddenly and traumatically increasing the load on the lower back. Likewise, loads that are unevenly distributed in their container (a non symmetric centre of gravity) place torsion on the spine.

Therefore, it is recommended that packaging —capture the contained items, to prevent movement within the container and hold the items in as symmetric an orientation as possible. For non symmetric loads, the heavier portion of the container should be closest to the handler in order to keep the centre of gravity as close to the spine as possible.

- Boxes, totes, and containers should have handles.

Handles or hand cut outs provide the best coupling between the handler and the object.

According to the 1991 Revised NIOSH Lifting Equation, the ideal handle design is 0.75"–1.5" in diameter, at least 4.5" long, and features a 2.0" hand clearance. Handles should be of a cylindrical shape with a smooth, nonslip surface. The optimal handhold cut out has a 1.5" or greater height, a length of at least 4.5", a semi oval shape, and a 2.0" hand clearance, a smooth nonslip surface, and at least a 0.25" wall thickness. Handholds near the bottom of the

container allow the handler to carry the load near knuckle height and minimize static muscle loading of the upper extremities.

The edges of the container should be rounded, not sharp. Sharp edges create opportunities for contact stress between the box and the hand, arm and body.

Analyzing manual materials handling tasks prioritize task analysis

Once we understand material flow, it is time to evaluate tasks. This should be done on a priority basis, first examining the worst and most strenuous tasks. The safety and health department should review accident statistics to determine priorities. The employees who perform the tasks being evaluated are a vital source of information. Ask employees for their views on where the most strenuous, demanding and dangerous materials handling tasks exist. Likewise, poll supervisors and other management personnel. This also is the time to examine the accident-investigation procedure to see if it is effective.

Analyze the job — tasks

Once priorities have been set, break the tasks down into elements, which are the simplest single actions needed to define the process at a particular stage of an operation. Among the considerations are:

- Recognize manual materials handling is more than just lifting. It also includes lowering, pushing, pulling, holding, carrying and transferring activities.
- Measure the frequency and duration of the task. Determine the frequency of the task in activities-per-minute. Be sure to note how the activity varies.

Be careful in estimating an average frequency which may be cyclical; that is, very fast then very slow. Note the average duration of the task.

Be aware of the trade off between frequency and weight. As loads become lighter and are lifted more frequently, fatigue becomes a factor. As loads become heavier and are lifted less frequently, considerations regarding the structure and strength of the back are important.

Allow the employee as much time as possible to complete the task, considering the needs of production.

Determine the type of pacing. Make additional allowances for forced pacing.

Minimize reach requirements. Design the operation to accommodate the smallest person's reach.

Avoid unnecessary material stacking, storing or placement for work-in-process material (such as neatly orienting parts in containers when they will be dumped out in the next operation).

Structure equipment to use gravity to move materials wherever feasible. Simplify tasks by combining operations and steps.

Analyze the job — load

The load consists of the item or collection of items handled, many of which are stored in containers.

Adjust all containers for the required volumes. Use large containers for high-flow volume and small containers for low volume.

Avoid using large containers for low-volume materials to reduce the need for workers to reach. Remove handling uncertainties. Remove an employee's doubt about whether he or she should manually or mechanically handle an object by using obviously small and large containers or parts.

Plan for incoming materials to arrive in suitable containers to minimize product handling.

Ask customers how you can best design product-needs packaging to meet their materials handling needs.

Reduce deadweight ratio of containers. Consider the weight of the container which must be repeatedly handled and transferred vs. the parts inside.

The weight of the container should be minimal compared to the weight of the product. Keep manually handled loads as small as possible, paying attention to the width and length. To prevent obstructed vision, load height should be 30 inches or less when manually handled.

The load centre of gravity (or balancing point) should be as close as possible to the person handling it. Stress on the back increases as the distance from your centre of gravity increases. For example, a 10-pound dictionary held 30 inches away from the body's centre of gravity would be the equivalent of a compact 50-pound load held close to the body.

Ensure that the load will be easy to grip. This can be accomplished by ordering cardboard boxes with handle cut outs; using containers with handles, lift straps or textured containers; and avoiding awkwardly designed items.

Stabilize contents in boxes and containers to reduce surprises. Insert vertical baffles or dividers, balancing the weight in a box or using packing materials to avoid shifting parts.

Minimize the potential for injury by protecting the employee from loads with sharp edges or projections. Potential for injury also exists with reactive loads, such as metal shavings.

Equipment

Consider the use of mechanical aids whenever possible to assist employees in their materials-handling needs.

Examples include:

- Pallet jack; • Lift table; • Two-wheeled hand truck; • Lift and tilt table; • Four-wheeled

cart;

- Winch; • Motorized hand truck; • Manipulator; • Hoist; • Positioned; • Crane; • Upended;

- Conveyor; • Dumper; • Chute; • Powered industrial vehicle.

Try to incorporate concepts that fit the job to the worker. Consider maintenance and setup needs when planning, designing, purchasing and installing equipment. Build equipment around materials handling requirements. The person who specifies a materials handling device should understand and clearly define usage expectations and desired outcomes.

This includes, but is not limited to, identifying:

- What will be carried (assessing size, weight, and other pertinent parameters)
- Overall weight and size capacity demands (using worst case load weight and size estimates)
- The terrain and anticipated travel path (identifying the presence of ramps, severe floor irregularities, steps, or other obstacles)
- Pertinent environmental conditions (extremes in temperature, water, or chemical exposures, etc.)

- How frequently the unit will be used (infrequently to constantly)
- Information pertaining to the people who will use the device (user population characteristics versus load and device characteristics), as necessary and appropriate

Such detailed information will help ensure that the specified device will fit the task requirements, reduce ergonomic risk factors, and reduce the human burden. Improperly designed or specified material handling aids have the potential to slow down work, lead the user to abandon the unit, or, worse, result in injury to the handler and perhaps to others. Choosing the right equipment can make work less physically taxing, reduce material handling risk factors, and make performing the task more acceptable to a wider range of people.

There is a host of material handling technologies available, including cranes, hoists, and monorails for lifting, lowering, and transporting; manipulators for picking and orienting; and work positions and lift tables for lifting, lowering, and rotating objects. Carts, dollies, and trucks are used for transporting loads, and a wide variety of tools and equipment, intended to reduce physical stressors associated with manual handling tasks, are available. Examples include conveyors, totes, flow racks, and ball transfers. Often teaming a combination of handling devices to work in concert as a system is desirable and should be considered. An example of this would be the use of a lift table used in conjunction with a conveyor and ball transfer to move materials from a receiving department through an incoming inspection process area.

Work scheduling

Bring only enough material to complete the job in the immediate work area. Extra material will either need additional handling to get it back to storage or will create congestion. Likewise, too little will require extra handling.

Consider the following, whenever possible, in jobs with considerable manual materials handling:

- Rotate employees from less strenuous jobs;
- Split work among two or more employees;
- Institute appropriate work/rest schedules.

Provide the worker with specific training in the following areas:

- Using mechanical handling aids. Employees may avoid mechanical aids because they simply do not know how to use them;
- Recognizing materials handling problems in the workplace;
- Identifying procedures that can prevent excessive manual materials handling;
- Proper body mechanics.

Remember that requiring employees to use particular lifting techniques — like the squat

Lift— has not been shown to be of any significant value. It is not recommended.

However, training on manual handling techniques should be part of a comprehensive back injury reduction program (even though lifting training alone is not effective in reducing back injuries).

Environment

Review work areas for proper illumination levels. Poor lighting can contribute to accidents and injuries, and diminish quality of products.

Make allowances for weather conditions including the following:

- Issue appropriate clothing, including gloves;

- Take measures to prevent cold and heat stress;
- Maintain aisles;
- Shield storage areas from mud and snow.

Evaluate noise levels to ensure that workers can hear and heed mechanical handling warning signals. Be sure air-contaminant levels are not excessive. This can be achieved through routine monitoring programs in high-exposure areas.

Recommend, review and implement changes

Once workers, staff and line personnel have identified problems, they must be acted upon. At this point, deficiencies have been identified with possible solutions in mind.

The process is broken down into the following stages:

- **Prioritize** — Priorities are categorized by the degree of hazard and risk associated with materials handling. These are determined as part of the initial management analysis of the

Maintenance of material handling equipment

The proper maintenance of material handling equipment is extremely essential for preventing the occurrence of bottle neck or points of congestions production line flow can be maintained only if the material handling equipment is in proper working order. Out of money maintenance techniques available preventive maintenance is one of the best maintenance techniques suggested in case of material handling equipment. Preventive maintenance helps to keep the material handling equipment always running conditions there by minimizing the interruption during operation. A periodic inspection and minor alignments may be adequate to prevent the equipment breakdown. Preventive maintenance also includes lubrication adjustment and repair.

There are three stages of preventive maintenance and they are

- Inspection
- Repair and
- Overhaul

Accounting for Materials Handling Costs

The cost of materials handling arises from two sources: the cost of owning and Maintaining equipment and the cost of operating the system. General cost accounting practice classifies the cost of handling materials as an indirect cost or overhead. This classification is based on the position that the movement of the materials does not contribute to their physical change or add value to them as a product or as a component part thereof.

In some manufacturing situations, such as a carbon black plant where the material is constantly moving during the production process, this contention of the cost accountants might be challenged. However, the problem of classification of unit handling costs of most situations is more of an academic than a practical nature.

Relation of Materials Handling to Flow of Material and Plant Layout

The pattern of flow of materials in a plant definitely affects the materials handling costs. The production process should be so planned and the machines and benches so arranged that the handlings of materials are reduced to a minimum with as little backtracking of goods as possible. The type of manufacturing is a major factor in this respect.

MISCELLANEOUS EQUIPMENTS:

- Cupola furnace charger
- Mobile lifting frames
- Hoppers
- Crushers
- Feeders
- Dumpers
- Ship loaders
- Wagon Tippers
- Escalators
- Apron And Scraper
- Excavator
- Hosting equipment
- Air cushion handling frames